

(19) World Intellectual Property Organization
International Bureau



(43) International Publication Date
3 June 2010 (03.06.2010)

(10) International Publication Number
WO 2010/062693 A2

(51) International Patent Classification:
A61B 17/00 (2006.01)

(21) International Application Number:
PCT/US2009/062789

(22) International Filing Date:
30 October 2009 (30.10.2009)

(25) Filing Language: English

(26) Publication Language: English

(30) Priority Data:
61/109,822 30 October 2008 (30.10.2008) US
61/143,748 9 January 2009 (09.01.2009) US
12/608,773 29 October 2009 (29.10.2009) US
12/608,769 29 October 2009 (29.10.2009) US

(71) Applicant (for all designated States except US): **AB-BOTT VASCULAR INC.** [US/US]; 3200 Lakeside Drive, Santa Clara, CA 95054-2807 (US).

(72) Inventors; and

(75) Inventors/Applicants (for US only): **MEHL, Douglas, H.** [US/US]; 238 Santa Clara Ave., Redwood City, CA 94061 (US). **ROORDA, Wouter, E.** [NL/US]; 36 Roosevelt Circle, Palo Alto, CA 94306 (US). **MCCRISTLE, Kelly, J.** [US/US]; 437 8th Avenue, Menlo Park, CA

94025 (US). **CLARK, Ian, J.** [GB/US]; 6595 Crest Top Drive, West Bloomfield, MI 48322 (US). **VOSS, Laveille, K.** [US/US]; 2832 Hallmark Dr., Belmont, CA 94002 (US). **DING, Ni** [US/US]; 4103 Cortona Ct., San Jose, CA 95135 (US).

(74) Agents: **ROY, Frasser, D.** et al.; Workman Nydegger, 60 East South Temple, 1000 Eagle Gate Tower, Salt Lake City, UT 84111 (US).

(81) Designated States (unless otherwise indicated, for every kind of national protection available): AE, AG, AL, AM, AO, AT, AU, AZ, BA, BB, BG, BH, BR, BW, BY, BZ, CA, CH, CL, CN, CO, CR, CU, CZ, DE, DK, DM, DO, DZ, EC, EE, EG, ES, FI, GB, GD, GE, GH, GM, GT, HN, HR, HU, ID, IL, IN, IS, JP, KE, KG, KM, KN, KP, KR, KZ, LA, LC, LK, LR, LS, LT, LU, LY, MA, MD, ME, MG, MK, MN, MW, MX, MY, MZ, NA, NG, NI, NO, NZ, OM, PE, PG, PH, PL, PT, RO, RS, RU, SC, SD, SE, SG, SK, SL, SM, ST, SV, SY, TJ, TM, TN, TR, TT, TZ, UA, UG, US, UZ, VC, VN, ZA, ZM, ZW.

(84) Designated States (unless otherwise indicated, for every kind of regional protection available): ARIPO (BW, GH, GM, KE, LS, MW, MZ, NA, SD, SL, SZ, TZ, UG, ZM, ZW), Eurasian (AM, AZ, BY, KG, KZ, MD, RU, TJ, TM), European (AT, BE, BG, CH, CY, CZ, DE, DK, EE,

[Continued on next page]

(54) Title: CLOSURE DEVICE

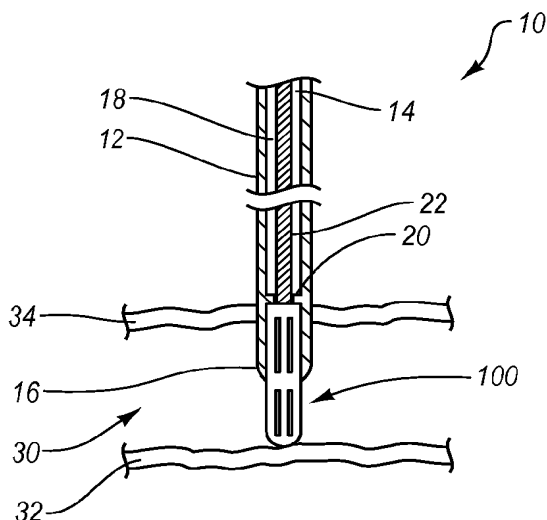

Fig. 1

(57) Abstract: A closure device for closing an opening in tissue is provided. The closure device according the present invention includes a delivery system for deploying a closure element, wherein the closure element is movable between a delivery configuration and a deployed configuration to close an opening in tissue. The closure device of the present invention may further include a charge of hemostatic material.

WO 2010/062693 A2



ES, FI, FR, GB, GR, HR, HU, IE, IS, IT, LT, LU, LV, MC, MK, MT, NL, NO, PL, PT, RO, SE, SI, SK, SM, TR), OAPI (BF, BJ, CF, CG, CI, CM, GA, GN, GQ, GW, ML, MR, NE, SN, TD, TG).

Published:

— *without international search report and to be republished upon receipt of that report (Rule 48.2(g))*

CLOSURE DEVICE

CROSS REFERENCE

This application claims the benefit of, and priority to, United States Provisional
5 Patent Application Serial No. 61/109,822, filed on October 30, 2008 and entitled
“CLOSURE DEVICE,” and United States Provisional Patent Application Serial No.
61/143,748, filed on January 9, 2009 and entitled “CLOSURE DEVICE,” both of which
are incorporated in their entireties herein by this reference.

This application also claims priority to U.S. Patent Application No. 12/608,773
10 filed on October 29, 2009 and entitled “CLOSURE DEVICE,” which claims the benefit
of, and priority to, United States Provisional Patent Application Serial No. 61/109,822,
filed on October 30, 2008 and entitled “CLOSURE DEVICE,” and United States
Provisional Patent Application Serial No. 61/143,748, filed on January 9, 2009 and
entitled “CLOSURE DEVICE,” all of which are incorporated in their entireties herein by
15 this reference.

This application also claims priority to U.S. Patent Application No. 12/608,769
filed on October 29, 2009 and entitled “CLOSURE DEVICE,” which claims the benefit
of, and priority to, United States Provisional Patent Application Serial No. 61/109,822,
filed on October 30, 2008 and entitled “CLOSURE DEVICE,” and Serial No.
20 61/143,748, filed on January 9, 2009 and entitled “CLOSURE DEVICE,” all of which are
incorporated in their entireties herein by this reference.

BACKGROUND

1. The Field of the Invention

25 The present disclosure relates generally to systems, devices, and methods for
blocking an opening in body lumens. More particularly, the present disclosure relates to
techniques for percutaneous closure of arterial and venous puncture sites, which are
usually accessed through a tissue tract.

30 2. The Relevant Technology

A number of diagnostic and interventional vascular procedures are now performed
transluminally. A catheter is introduced to the vascular system at a convenient access
location and guided through the vascular system to a target location using established
techniques. Such procedures require vascular access, which is usually established during

the well-known Seldinger technique. Vascular access is generally provided through an introducer sheath, which is positioned to extend from outside the patient body into the vascular lumen. When vascular access is no longer required, the introducer sheath is removed and bleeding at the puncture site stopped.

5 One common approach for providing hemostasis (the cessation of bleeding) is to apply external force near and upstream from the puncture site, typically by manual compression. This approach suffers from a number of disadvantages. For example, the manual compression procedure is time consuming, frequently requiring one-half hour or more of compression before hemostasis is achieved. Additionally, such compression
10 techniques rely on clot formation, which can be delayed until anticoagulants used in vascular therapy procedures (such as for heart attacks, stent deployment, non-optimal PTCA results, and the like) wear off. The anticoagulants may take two to four hours to wear off, thereby increasing the time required before completion of the manual compression procedure.

15 Further, the manual compression procedure is uncomfortable for the patient and frequently requires analgesics to be tolerable. Moreover, the application of excessive pressure can at times totally occlude the underlying blood vessel, resulting in ischemia and/or thrombosis. Following manual compression, the patient typically remains recumbent from four to as much as twelve hours or more under close observation to
20 assure continued hemostasis. During this time, renewed bleeding may occur, resulting in blood loss through the tract, hematoma and/or pseudo-aneurysm formation, as well as arteriovenous fistula formation. These complications may require blood transfusion and/or surgical intervention.

 The incidence of complications from the manual compression procedure increases
25 when the size of the introducer sheath grows larger, and/or when the patient is anticoagulated. The compression technique for arterial closure can be risky, and is expensive and onerous to the patient. Although the risk of complications can be reduced by using highly trained individuals, dedicating such personnel to this task is both expensive and inefficient. Nonetheless, as the number and efficacy of translumenally
30 performed diagnostic and interventional vascular procedures increases, the number of patients requiring effective hemostasis for a vascular puncture continues to increase.

 To overcome the problems associated with manual compression, the use of bioabsorbable sealing bodies is one example approach that has been proposed. Generally, this example approach relies on the placement of a thrombogenic and bioabsorbable

material, such as collagen, at the superficial arterial wall over the puncture site. While potentially effective, this approach suffers from a number of problems. For example, bioabsorbable sealing bodies may lack a solid mechanical attachment of the sealing body to the tissue. Due to the lack of a solid mechanical attachment, the sealing body can wander within the tissue tract or move out of the puncture site, thus causing late bleeds. Conversely, if the sealing body wanders and intrudes too far into the arterial lumen, due to the lack of a solid mechanical attachment, intravascular clots and/or collagen pieces with thrombus attached can form and embolize downstream, causing vascular occlusion.

In addition to not having a solid mechanical attachment to the tissue, the sealing bodies may rely upon expandable materials to achieve hemostasis. Again, the expandable materials lack the security of a hard mechanical closure, thus potentially causing late bleeds and prolonging hemostasis.

BRIEF SUMMARY

This Summary is provided to introduce a selection of concepts in a simplified form that are further described below in the Detailed Description. This Summary is not intended to identify key features or essential features of the claimed subject matter, nor is it intended to be used as an aid in determining the scope of the claimed subject matter. Embodiments of the present disclosure provide systems, methods and devices for closing an opening in tissue. Embodiments of the disclosure can be configured to close an opening within a body lumen.

In one example embodiment, a device for closing an opening in tissue includes a tubular body member having a wall thickness, a proximal end, and a distal end. The tubular body member of the device may include slits formed within the tubular member through the wall thickness. The slits are arranged above and below a waist portion located between the proximal end and distal end of the tubular body member.

In another example embodiment, a device for closing an opening in a body lumen wall includes a tubular body element having a first portion, a second portion, and a waist portion located between the first portion and second portion. The first and second portions have a delivery configuration and a deployed configuration. When the first and second portions are in the delivery configuration they have a delivery cross-sectional dimension, and when the first and second portions are in a deployed configuration they have a deployed cross-sectional dimension. The deployed cross-sectional dimension is larger than the delivery cross-sectional dimension.

Another example embodiment discloses a system for closing an opening in a body lumen. The system includes a closure element having a delivery configuration and a deployed configuration. The system further includes an actuator that is coupled to the closure element and operatively associated with a handle assembly. The handle assembly
5 includes a rotatable handle element that may be inserted into a hub member such that when the handle element is rotated, the closure element changes from the delivery configuration to the deployed configuration.

In another example embodiment, a method for closing an opening in a body lumen is disclosed. The method includes inserting a closure device into an opening in a body
10 lumen wall, the closure device including a closure element and actuator. After inserting the closure device, a force is applied to the closure element by way of the actuator such that a first portion of the closure element changes from a delivery configuration to a deployed configuration. Next, a second force may be applied to the closure element by way of the actuator such that a second portion of the closure element changes from a
15 delivery configuration to a deployed configuration.

In one example embodiment, a device for closing an opening in a wall of a body lumen may include a closure element with a first flange and a second flange. Both the first flange and the second flange have a delivery cross-sectional dimension and a deployed cross-sectional dimension. The device further includes a first coupler element
20 disposed on the first flange and a second coupler element disposed on the second flange, the first and second coupler elements cooperating to couple the first flange to the second flange.

In another example embodiment, a closure element for closing an opening in a body lumen includes a proximal flange with a first coupler element and a distal flange
25 with a second coupler element. The closure element may also include a pull cord that is operatively associated with the distal flange such that the second coupler element may be coupled to the first coupler element by pulling the pull cord.

Another example embodiment includes a closure element that has a delivery configuration and a deployed configuration and is used to close an opening in a wall of a
30 body lumen. The closure element includes a first flange with a delivery configuration and a deployed configuration such that the first flange can pass through the opening in the wall of the body lumen when in the delivery configuration, but not when in the deployed configuration. The closure element further includes a second flange having a delivery configuration and a deployed configuration, wherein the second flange cannot pass

through the opening in the wall of the body lumen when in the deployed configuration. Moreover, the closure element may include a coupler portion positioned between the first flange and the second flange, the coupler portion having a cross-sectional dimension substantially equal to or smaller than the opening.

5 A further embodiment includes a system for closing an opening in a body lumen that includes a closure element, an actuator coupled to the closure element, and a handle assembly. The handle assembly may include a handle element operatively associated with a hub member such that the actuator moves the closure element from a delivery configuration to a deployed configuration upon rotation of the handle element.

10 Another embodiment of the invention includes a method of closing an opening in tissue that includes inserting a closure device into an opening formed in tissue. Applying a force to the actuator to change the closure element from a first configuration to a second configuration.

These and other advantages and features of the present disclosure will become
15 more fully apparent from the following description and appended claims, or may be learned by the practice of the disclosure as set forth hereinafter.

BRIEF DESCRIPTION OF THE DRAWINGS

To further clarify the above and other advantages and features of the present
20 disclosure, a more particular description will be rendered by reference to specific embodiments which are illustrated in the appended drawings. It is appreciated that these drawings depict only typical embodiments of the disclosure and are therefore not to be considered limiting of its scope. The embodiments will be described and explained with additional specificity and detail through the use of the accompanying drawings in which:

25 Figure 1 is a cross-sectional view of the closure device in accordance with one embodiment of the present invention;

Figure 2A is a close-up cross-sectional view of an example embodiment of a closure device in accordance with the present invention;

30 Figure 2B is a close-up cross-sectional view of an example embodiment of a closure device in accordance with the present invention and further illustrating a locking mechanism formed therewith;

Figure 2C is a cross-section view of an example embodiment of a closure element in a deployed configuration;

Figures 3 through 6 illustrate the use of an example closure device in accordance with the present invention;

Figures 7A through 9B illustrate various embodiments of a closure element in accordance with the present invention;

5 Figures 10 and 11 are cross-sectional views of an alternative embodiment of a closure device including a charge of a hemostatic material;

Figure 12 is a flow chart showing an example method of closing an opening in tissue in accordance with the present invention;

10 Figure 13A is an exploded illustration of a delivery system of one embodiment of the present invention;

Figure 13B is a top view of a portion of the delivery system of Figure 13A according to one embodiment of the present invention;

Figure 13C is another illustration of the delivery system of Figure 13A according to one embodiment of the present invention;

15 Figure 13D is a cross-section illustration of a portion of the delivery system of Figure 13A;

Figure 13E is a further illustration of the delivery system of Figure 13A;

Figure 13F is a yet further illustration of the delivery system of Figure 13A;

20 Figure 13G is a perspective illustration of the delivery system of Figure 13A in combination with an introducer sheath according to another embodiment of the present invention;

Figure 14 illustrates an example embodiment of a closure element in accordance with the present disclosure;

25 Figures 15 and 16 illustrate example components of an example embodiment of the closure element of Figure 14;

Figure 17 is a partial cross-sectional view of a delivery system and the closure element of Figure 14;

Figure 18A is an illustration of the closure element of Figure 14 partially deployed;

30 Figure 18B is an illustration of the closure element of Figure 14 fully deployed; and

Figure 19 is a flow chart showing an example method of closing an opening in tissue in accordance with the present disclosure.

DETAILED DESCRIPTION

In accordance with the present disclosure, there is provided closure devices configured to close an opening in tissue. The closure devices described herein may be formed of a bioabsorbable material or may be formed of a biocompatible material. It is further contemplated that the closure device may be coated with a covering membrane and/or another biocompatible coating as will be described in greater detail below. In one embodiment, the closure device may be configured to be received within and deployed from the lumen of a medical sheath, for example, a physician may utilize a 6 French sheath. However, it can be understood that embodiments of the closure device may be configured to be received within multiple sizes and configurations of sheaths and should not be limited to the example above and will accommodate newer and yet to be developed endoluminal techniques including venous techniques.

Figure 1 illustrates one example embodiment of a closure device 10. As shown in Figure 1 the closure device 10 may include an elongate member 12 that has a proximal end 14 and a distal end 16. The elongate member 12 may also include a passage 18 that extends from the proximal end 14 towards the distal end 16. Within the passage 18 of the elongate member 12, a protrusion 20 extends into the passage 18, thus reducing the cross-sectional dimension of the passage 18 at a location that is between the proximal end 14 and the distal end 16 of the elongate member 12. The closure device 10 further includes an actuator 22 that extends through the passage 18 of the elongate member 12. A closure element 100 extends beyond the elongate member 12 and may be coupled to the actuator 22.

In operation, the closure device 10 may be inserted into a body lumen 30 as illustrated in Figure 1. In one embodiment, the elongate member 12 and the closure element 100 pass through the proximal luminal wall 34 of the body lumen 30. While within the body lumen 30 the closure element 100 is changed from a delivery configuration, as illustrated in Figure 1, to a deployed configuration as illustrated in Figure 2C. While in the deployed configuration the closure element 100 is able to block or otherwise close a puncture in the proximal luminal wall 34.

Referring back to Figure 1, the structure of the closure device 10 will be discussed in more detail. In particular, the closure device 10 may have configurations and characteristics that vary from one embodiment to the next. For example, the elongate member 12 is one aspect of the closure device 10 that may vary from one embodiment to the next. In particular, the elongate member 12 may have various geometric

configurations. As illustrated in Figure 1, the elongate member 12 may have a substantially circular cross-sectional geometric configuration. In other embodiments, however, the cross-sectional configuration of the elongate member 12 may vary and take various other configurations such as oval, square, triangular or any other configuration or
5 combination of configurations.

Along with the various cross-sectional configurations of the elongate member 12, the passage 18 may also have various cross-sectional configurations. The cross-sectional configuration of the elongate member 12 may or may not match the cross-sectional configuration of the passage 18. Moreover, the cross-sectional configurations of the
10 elongate member 12 and the passage 18 may vary from the proximal end to the distal end of the elongate member 12.

Notwithstanding variations in the geometric configuration, the elongate member 12 may be configured to retain the closure element 100 at the distal end 16 of the elongate member 12. In one example embodiment, illustrated in Figure 1, the elongate member 12
15 further includes a protrusion 20 that protrudes inwardly into the passage 18 such that the closure element 100 is not permitted to pass the protrusion 20. The protrusion 20, as illustrated in Figure 1, also may include a passage such that the actuator 22 may pass through the protrusion section 20 and contact or couple to the closure element 100.

In one example, and as illustrated in Figure 1, the closure element 100 is generally
20 allowed to be inserted only about halfway into the passage 18 of the elongate member 12 and thereafter is blocked from being inserted further into the elongate member 12 by the protrusion 20. The location of the protrusion 20 may vary from one embodiment to the next. In other example embodiments, the protrusion 20 may be positioned more proximally within the passage 18 of the elongate member 12, or alternatively, the
25 protrusion 20 may be positioned more distally within the elongate member 12. Thus, the position of the protrusion 20 may allow the closure element 100 to either be further inserted into the elongate member or have more of the closure element 100 positioned outside the elongate member 12.

In addition to variations of the protrusion 20 within the passage 18 of the elongate
30 member 12, the distal end 16 of the elongate member 12 may also vary. For example and as illustrated in Figure 1, the distal end 16 of the elongate member 12 may have a radius. This radius, for instance, may assist when inserting the elongate member 12 into a tissue tract and subsequently into the body lumen 30 through the proximal luminal wall 34. In other example embodiments, the distal end 16 of the elongate member 12 may have

various other configurations. For example, they may have various ranges of radii as well as various other geometric configurations, for example, square, triangular, or rectangular.

In addition to the geometric configuration variations, the elongate member 12 may also have various material characteristics. For example, in one embodiment the elongate member 12 may be formed of a rigid material such as a stainless steel or other biocompatible material that is rigid. Alternatively, the elongate member 12 may be formed of a flexible material such as those materials utilized to form catheter shafts, introducer sheaths, or other medical devices. Suitable materials include polyvinyl chloride (PVC), polyethylene (PE), PTFE, nylon, or any other similar materials.

As discussed, the actuator 22 may extend through the elongate member 12. The actuator 22 is another aspect of the closure device 10 that may vary from one embodiment to the next. As shown in Figure 1, the actuator 22 extends through the passage 18 of the elongate member 12 and couples to or attaches to the closure element 100. One way in which the actuator 22 may vary is the cross-sectional geometric configuration of the actuator. Figure 1 illustrates an actuator 22 that has a substantially circular cross-sectional configuration. In other example embodiments, the cross-sectional geometric configuration of the actuator 22 may vary and include configurations such as square, triangular, rectangular or any other geometric configuration. In one example embodiment, the geometric configuration of the actuator 22 may be configured to match the cross-sectional geometric configuration of the passage 18 within the elongate member 12.

Another way in which the actuator 22 may vary is the material from which the actuator 22 is made. For example, the actuator 22 may be made from a rigid material such as stainless steel or other biocompatible materials that are rigid. Alternatively, the actuator 22 may be formed of a flexible material, for example, if the elongate member 12 is made from a flexible material. Examples of flexible actuator 22 materials include polyvinyl chloride (PVC), polyethylene (PE), PTFE, nylon, or similar materials. Generally, the actuator 22 material may be made from any material that is able to have enough strength and structural properties to change the closure element 100 from a delivery configuration, as shown in Figure 2A, to a deployed configuration, as shown in Figure 2C.

Another way in which the actuator 22 may vary is the way in which it connects to or attaches to the closure element 100. Figure 2B illustrates a cross-sectional view of the closure element 100 that shows one example of connecting the actuator 22 to the closure element 100. For example, actuator 22 may include a coupler element 24 that is

configured to couple to the distal end 106 of the closure element 100. In one example embodiment, and as illustrated in Figure 2B, the coupler element 24 includes a section that has a larger cross-sectional dimension than the actuator 22. In this example, the coupler element 24 may interface with the distal end 106 of the closure element 100 such that the coupler element 24 is held by the material of the closure element 100 (e.g., the closure element 100 material surrounds the coupler element 24. In other example embodiments, the coupler element may simply attach to or couple to the distal end 106 of the closure element 100 by an adhesive or other bonding means.

In addition to the coupler element 24, the actuator 22 may also include a locking element 26, as illustrated in Figure 2B. The locking element 26 may vary from one embodiment to the next. For example, and as illustrated in Figure 2B, the locking element 26 has a triangular configuration, however, in other example embodiments the geometric configuration of the locking element may take various forms such as square, rectangular, oval, circular or any other configuration.

In particular, the geometric configuration of the locking element 26 is configured such that the locking element 26 and the proximal end 104 of the closure element 100 cooperate to lock the closure element 100 in the deployed configuration. For example, and as illustrated in Figures 2B and 2C, the locking element 26 may be pulled through the proximal end 104 of the closure element 100. Once pulled through the proximal end 104 of the closure element 100, the locking element 26 and/or the proximal end 104 of the closure element 100 may be configured such that the locking element 26, in combination with the proximal end 104 of the closure element 100, restricts the actuator from moving distally with respect to the closure element 100. In other words the locking element 26 may be configured to facilitate removal of the locking element 26 from within the closure element 100, but after removal from the closure element 100, the locking element 26 may not be allowed to re-enter the closure element 100.

Notwithstanding the various configurations and characteristics of both the elongate member 12 and the actuator 22, the closure element 100 may be configured to be operatively associated with the elongate member 12 and the actuator 22 in order to be delivered and deployed in an opening within a body lumen. Continuing now with Figures 2A, 2B, and 2C, the closure element 100 will be discussed in more detail. As illustrated in Figure 2A, the closure element 100 may include a body member 102 that has a proximal end 104 and a distal end 106. The body member 102 may also include a waist portion 108 that separates a plurality of proximal slits 110 from a plurality of distal slits

112. Moreover, the closure element 100 may have a delivery configuration, as illustrated in Figure 2A, and a deployed configuration, as illustrated in Figure 2C.

As with other aspects of the closure device 10, the closure element 100 may vary from one embodiment to the next. One way in which the closure element 100 may vary is the cross-sectional configuration of the closure element 100 body member 102. For example, and as illustrated in Figure 2A, the body member 102 may have a generally cylindrical cross-sectional configuration. In other example embodiments, the cross-sectional configuration of the body member 102 may take various forms such as square, rectangular, triangular or any other cross-sectional configuration.

Another way in which the closure element 100 may vary is the geometric dimensions of the proximal slits 110 and/or distal slits 112. For example, the geometric configuration of the upper and lower slits 110 and 112, as shown in Figure 2A, may be a generally rectangular configuration. However, in other example embodiments the geometric configuration of the proximal slits 110 and/or the distal slits 112 may take various other geometric configurations such as more square, triangular, oval or any other configuration or combination configurations. The slits may be formed within the wall of the body member 102 using known manufacturing techniques such as cutting, laser cutting, water jet cutting. Alternatively, the slits may be integrally formed within the body member 102 during manufacturing such as through the use of injection molding.

Furthermore, and as illustrated in the example embodiment in Figure 2A, the proximal slits 110 may have substantially the same configuration and dimensions as the distal slits 112. In other example embodiments, however, the proximal slits may have a different geometric configuration and/or dimension compared to the distal slits 112. For example, in one embodiment, the proximal slits 110 may have a different length and width as the distal slits 112, or the proximal slits 110 may have a different geometric configuration relative to the distal slits 112.

In addition to variations between the proximal slits 110 and the distal slits 112, the geometric configuration and the dimensions of the proximal slits 110 and/or distal slits 112 may vary from one slit to the next. For instance, the upper slits 110 may have a variety of different sized and configured slits that make up the plurality of upper slits 110. Similarly, the lower slits 112 may be made up of a variety of different sized and configured individual slits.

Another way in which the proximal slits 110 and distal slits 112 may vary is the alignment configuration between the proximal slits 110 with respect to the distal slits 112.

For example, as illustrated in Figure 2A, the proximal slits 110 may be substantially aligned with the distal slits 112. However, in other example embodiments, the proximal slits 110 may be positioned such that the proximal slits are misaligned with the distal slits 112. In the same respect, the number of proximal slits 110 compared to the number of distal slits 112 may vary from one embodiment to the next. As shown in Figure 2A, there are an equal number of proximal slits 110 relative to the number of distal slits 112. In other examples, however, the closure element 100 may have more proximal slits 110 compared to distal slits 112. For example, a closure element may be configured such that there are six distal slits equally spaced around the body member 102 of the closure element 100, while there are only four proximal slits 110 positioned and equally spaced around the body member 102 of the closure element 100.

As can be understood, the spacing between each individual slit may also vary from one embodiment to the next, as well as from one slit to the next. For example, and as previously mentioned, the upper and/or lower slits 110 and 112 may have the slits positioned and equally spaced around the body member 102. Alternatively, the slits may be positioned around the body member 102 such that the spacing between slits varies.

The distance between the proximal slits 110 and the distal slits 112 is another aspect of the closure element 100 that may vary from one embodiment to the next. In one example embodiment, the distance between the proximal slits 110 and the distal slits 112 is a distance that would be approximately equal to the width of a body lumen wall. For example, the distance between the upper and distal slits may be equal to the width of the proximal lumen wall 34, illustrated in Figure 1. In this manner, the closure element 100, when in the deployed configuration, would assist in blocking an opening within the proximal lumen wall 34.

Figure 2B illustrates various other aspects of the closure element 100 that may vary from one embodiment to the next. For example, Figure 2B illustrates that the closure element 100 may include an aperture 105 located on the proximal end 104 of the body member 102. In one embodiment, the proximal end 104 of the body member 102 of the closure element 100 may be made of material that is flexible such that the locking element 26 of the actuator may be pulled in a proximal direction through the aperture 105 located on the proximal end 104 of the closure element 100. Moreover, the proximal end 104 of the body member 102 may have a geometric and/or material configuration that allows the locking element 26 or similar feature of the actuator to pass through in one

direction (i.e. the proximal direction) but not pass through in the opposite direction (i.e. the distal direction).

For example, the proximal end 104 may be configured with a plurality of cuts that are arranged in a generally circular pattern around the aperture 105 such that each cut extends away from the aperture along a radius line. The cuts may be formed at an angle such that the material on the proximal end 104 between the cuts are allowed to flex in a direction that would allow the locking element 26 to pass through the aperture 105 of the closure element 100. However, once the locking element 26 has passed through the aperture 105, the proximal end 104 material between the cuts is not permitted to flex to allow the locking element 26 to again pass through the aperture 105. In other words, the material at the proximal end 104 of the closure element 100 may only flex in one direction and thus resist movement of the locking element 26 in the distal direction after the locking element 26 has passed through the aperture 105.

The locking element 26, along with the configuration of the closure element 100 assist to change the closure element 100 from a delivery configuration, shown in Figures 1 and 2A, to a deployed configuration shown in Figure 2C. In one embodiment, the actuator 22 cooperates with the closure element 100 to collapse the body member 102 of the closure element such that the proximal slits 110 and the distal slits 112 allow the portions of the body member 102 between the proximal slits 110 and distal slits 112 to collapse and flex radially outwardly. Moreover, when in the deployed configuration, the actuator 22, with the locking element 26 and the coupler element 24 may cooperate with the closure element 100 such that the body member 102 of the closure element 100 may be changed into, and held locked in, the deployed configuration. Specifically, the locking element 26 cooperates with the coupler element 24 such that the body member 102 of the closure element 100 is held in place in the deployed configuration between the locking element 26 and the coupler element 24.

The deployed configuration of the closure element 100 may have various configurations. For example, in one embodiment, the deployed configuration of the closure element 100 may provide a clamping force upon the body lumen wall, thus holding the closure element 100 in place within the opening in the body lumen. Additional characteristics and configurations of the closure element 100 in the deployed configuration will be discussed with respect to Figures 6 through 9B.

Another way in which the closure element 100 may vary is the type of material used to make the closure element 100. In one embodiment the closure element 100 is

manufactured from a bioabsorbable, bioresorbable, bioerodible, and/or biodegradable material. Examples of suitable materials for use are metals, metal alloys, polymers or combinations thereof that decompose or biodegrade in a biological environment such as within a body lumen. For example, and not by limitation, suitable bioabsorbable materials may include magnesium, zinc, silicon, lithium, zinc titanium, magnesium lithium, polyglycolic acid (PGA), polyhydroxybutyric acid, polyL-Lactic acid (PLLA), polydilactidel glycolide acid, polydilactid acid, PolyDL Lactide-co-glycolide, Polylactic acid, Polylicolic acid, Polyhydroxyalkanoates or derivatives thereof and any combination thereof.

10 In addition to the various types of materials that may be used to manufacture the closure element 100, the closure element 100 may include additional material properties that may be useful. For example, the closure element 100 may be covered with a flexible membrane to aid in sealing the opening. The flexible membrane may be formed of a flexible bio-compatible or bioabsorbable material such as any of those that were described above. Moreover, the closure element 100 may further include a beneficial agent either disposed thereon as a coating or integrally formed within the absorbable material wherein the beneficial agent would be configured to aid in healing and/or reduce the potential for infection.

Moreover, material properties may be included in the closure element 100 to help a user place the closure element 100. For example, the closure component 100 may further include a radiopaque marker or radiopaque coating in order to aid the user in positioning the closure element 100 within the puncture site of the body lumen. The radiopaque marker may be formed within the wall of the body member 102 in the form of a rivet. Alternatively, a radiopaque coating may be disposed on the body member 102 as a thin coating of radiopaque metal such as gold, tantalum, alydium, platinum, uridium or similar metals.

Referring now to Figures 3 through 6, the operation of the closure device 10 will be explained in more detail. Initially, the closure device 10 is inserted in a tissue tract and disposed through an opening or puncture within a body lumen. For example and as shown in Figure 1, the closure device 10 may be disposed through the proximal lumen wall 34 of the body lumen 30. After disposing the closure device 10 through the opening in the proximal lumen wall 34 the closure element 100 may be changed from a delivery configuration to a deployed configuration.

In one embodiment, the process of changing the closure element 10 from a delivery configuration to a deployed configuration begins with positioning the closure element 100 within the elongate member 12 such that the distal slits 112 are located outside of the elongate member 12 and the proximal slits 110 are located within the elongate member 12. In one example, this position of the closure element 100 may correspond to the protrusion 20 located within the elongate member 12 as discussed above and as illustrated in Figure 3.

With the distal slits 112 positioned outside of the elongate member 12, the actuator 22 may be moved in the proximal direction (as indicated by the arrow in Figure 3) such that the portions of the body member 102 located in-between the distal slits 112 are forced to collapse, bend, and/or buckle and extend in an outward direction as shown in Figure 3. In particular, the actuator 22 may pull the distal end 106 of the closure element 100 in a proximal direction by way of the coupler element 24 that is coupled to the distal end 106 of the closure element 100. The distal slits 112 may weaken the body member 102 such that upon experiencing the force associated with pulling the distal end 106 of the closure element 100 in the proximal direction, the portions of the body member 102 in-between the distal slits 112 collapse, the collapsing portions of the body member 102 extending out from the closure element 100. On the other hand, because the proximal slits 110 are positioned within and stabilized by the elongate member 12, the portions of the body member 102 in-between the proximal slits 110 may not collapse.

Once the portions of the body member 102 in-between the distal slits 112 have collapsed, the closure device 10 may be moved in the proximal direction such that the deployed lower section of the closure element 100 is generally in contact with the inside portion of the proximal lumen wall 34, as illustrated in Figure 4. At this position, the deployed section of the closure element 100 is within the body lumen 30, the waist portion 108 of the closure element 100 extends through the opening in the proximal lumen wall 34, and the proximal slits 110 are located outside the body lumen 30.

When in this position, the elongate member 12 may be moved in a proximal direction relative to the closure element 100 such as to reveal or release the proximal slits 110 from the elongate member 12. In one example embodiment, the actuator 22 is held in substantially a constant position, while the elongate member 12 is pulled or otherwise moved in a proximal direction with respect to the closure element 100. Moreover, the distal end 16 of the elongate member 12 may be configured with a bias that applies a radially compressive force on the closure element 100. Thus, once the closure element is

released from the elongate member 12, the user may sense the release and/or feel that the resistance to the movement of the elongate member 12 has changed indicating that the proximal slits 110 have been released from the elongate member 12.

At this point the proximal slits 110 are now in position for the proximal portion of the closure element 100 to be deployed. As illustrated in Figure 5, the proximal portion of the closure element 100 is deployed by having the portions of the body member 102 in-between the proximal slits 110 collapse such that the portions of the body member 102 in-between the proximal slits 110 extend radially outwardly as illustrated in Figure 5. In order to deploy the upper portion of the closure element 100, the actuator 22 may be moved in a proximal direction (as illustrated by the arrow in Figure 5) thus applying a force to the closure element 100 that causes the portions of the body member 102 in-between the proximal slits 110 to collapse and extend outwardly.

Moreover, and as illustrated in Figure 5, during or after the deployment of the proximal portion of the closure element 100, the locking element 26 located on the actuator 22 may be pulled through the aperture 105 in the proximal end 104 of the closure element 100. The locking element 26 is then allowed to rest or push on the proximal end 104 of the closure element 100 such that the closure element is held in the deployed configuration between the locking element 26 and the coupler element 24 of the actuator.

Figure 6 shows a close-up view of a deployed closure element 100 within an opening of a body lumen 30. As shown in Figure 6, the proximal slits 110 and distal slits 112 have allowed the proximal and distal portions of the body member 102 to collapse, and thus the portions of the body member 102 in-between the slits have extended outwardly such that the proximal lumen wall 34 is located between the collapsed proximal portion and the collapsed distal portion of the closure element 100. The waist portion 108 of the body member 102 may be located at least partially within the opening in the proximal lumen wall 34 of the body lumen 30.

Figure 6 further illustrates that the deployed closure element 100 may be held in a deployed configuration by the coupler element 24 and the locking element 26. In particular, the locking element 26 cooperates with the coupler element 24 such that the closure element 100 is squeezed or otherwise restricted between the coupler element 24 and the locking element 26. In this way, the portions of the body member 102 that have collapsed are held in the collapsed or deployed configuration and are not permitted to return to the pre-collapsed or delivery configuration.

Once the closure element 100 is locked in the deployed configuration, the actuator 22 portion proximal to the locking element 26 may be severed or cut using a secondary cutting device or, alternatively, the actuator 22 may be configured such that upon application of another proximal force a weakened portion of the actuator 22 allows the actuator to break free at a location on the actuator 22 that is proximal to the locking element 26. The severed actuator 22 and the elongate member 12 are then removed from the tissue tract leaving the deployed closure element 100 within the puncture or opening within the body lumen 30.

Figures 7A through 8B illustrate various additional example embodiments of the closure element 100. For example, Figure 7A illustrates a closure element 100 that includes a body member 102 with a proximal end 104 and a distal end 106. The body member 102 has proximal slits 110 and distal slits 112 formed within the body member 102 of the closure element 100. The proximal slits 110 and the distal slits 112 may have various arrangements and alignments with respect to one another. The arrangement and alignment of the proximal slits 110 and the distal slits 112 may affect the deployed configuration of the closure element 100. Thus, the proximal slits 110 and the distal slits 112 may have almost any arrangement and alignment configurations that subsequently determine the deployed configuration of the closure element 100.

For example, and as illustrated in Figures 7A through 7B, the closure element 100 may take various forms. In particular, the example closure element 100, illustrated in Figure 7A, includes proximal slits 110 that are offset from the distal slits 112. In other words, the proximal slits 110 are not vertically aligned with the distal slits 112. This example offset arrangement of the proximal and distal slits 110 and 112 may result in the closure element 100 having a deployed configuration as illustrated in Figure 7B.

Specifically, when in the deployed configuration, the closure element 100 has upper extensions 114 and lower extensions 116. As illustrated in Figure 7B, the upper extensions 114 may be offset from the lower extensions 116 such that the upper extensions 114 and lower extensions 116 alternate as viewed from the distal end 106 of the closure element 100. In other example embodiments, the upper extensions 114 and lower extensions 116 may be configured such to have any pattern of alignment or arrangement with respect to one another or with respect to other portions of the closure element 100 depending on the alignment or arrangement of the proximal slits 110 with respect to the distal slits 112.

Figure 8A shows another alternative embodiment of the closure element 100 that varies the configuration of the proximal slits 110 and the lower slits 112 to produce another example of the deployed configuration of the closure element 100. As illustrated in Figure 8A, the closure element 100 has a body member 102 that has a proximal end 104 and distal end 106 and also includes a waist portion 108. The waist portion 108 is positioned between proximal slits 110 and distal slits 112. In this example embodiment, the proximal and distal slits 110 and 112 are curved or have a radius, as illustrated in Figure 8A. The curved proximal slits 110 and curved distal slits 112 produce curved upper and lower extensions 114 and 116 when the closure element 100 is changed into the deployed configuration. Moreover, and as illustrated in Figure 8B, the curved upper and lower extensions 114 and 116 may alternate one from another. As with the embodiment shown in Figure 7A, the curved upper and lower extensions 114 and 116 may have any alignment or arrangement configuration with respect to one another.

In addition to the two embodiments of the closure element 100, illustrated in Figures 7A through Figure 8B, the upper and distal slits 110 and 112 may have various other configurations such as a zigzag pattern, an oval pattern or any other pattern or configuration that would produce various arrangement and alignment configurations of the upper extensions 114 and/or lower extensions 116. Moreover, there can be any combination between the proximal slits 110 and the distal slits 112. For example, the proximal slits may take on a more rectangular configuration, as shown in Figure 7A, and the distal slits 112 may take on a curved configuration as shown in 8A. Thus, the deployed configuration of the closure element 100 may have upper extensions 114 that are rectangular, as shown in 7B, and lower extensions 116 that are curved, as shown in Figure 8B.

Although Figures 7A through 8B addresses various example configurations of the closure element 100 that have proximal and distal slits 110 and 112, the closure element 100 may be configured to not contain any slits. For example, Figures 9A and 9B show an example embodiment of a closure element 100 that does not include any proximal or distal slits; however, the closure element 100 is still able to collapse such to form the deployed configuration of the closure element 100. In particular, the sidewall of the closure element 100, as illustrated in Figure 9B, may include indentations 118 or other areas within the wall that create natural weaknesses or breaking points. The indentations 118 within the closure element wall 120 may be configured such that when a compressive

force is applied from the actuator 22, the closure element 100 collapses around the weakened portions of the indentation 118.

The indentations 118, shown in Figure 9B, may vary from one embodiment to the next. For example, the number of indentations that are located on the sidewall 120 of the closure element 100 may vary. In one example embodiment illustrated in Figure 9B, the sidewall 120 of the closure element 100 includes two indentations 118. Each indentation 118 would produce extensions when the closure device is changed to the deployed configuration, thus two extensions (for example an upper and lower extension) would be made from the example embodiment shown in Figure 9B. However, in other example embodiments, more or less indentations may be used in order to create various or multiple sections of that collapse to form a barrier within an opening of a body lumen.

Figures 10 and 11 show another optional embodiment of a closure device 200. As illustrated in Figure 10, closure device 200 may include an elongate member 12 that has a passage 18 extending through from a proximal end to a distal end. The elongate member 12 may be configured to accept and retain a closure element 100. The closure element may include a proximal end 104, a distal end 106, and a waist portion 108 that is located between the proximal end 104 and the distal end 106. In one embodiment, the closure element 100 may contain proximal slits 110 and distal slits 112, as previously discussed. Closure device 200 further includes an actuator 22 that is connected to the closure element 100. The actuator 22 is associated with a second actuator 40. Located within the passage 18 within the elongate member 12 may be a hemostatic agent 50.

In one example embodiment of the closure device 200, the second actuator 40 has a slightly larger cross-sectional dimension than the cross-sectional dimension of the actuator 22. In this way a space is located in the passage 18 between the elongate member 12 and the actuator 22 such that a hemostatic agent 50 may be placed next to the actuator 22. Moreover, the second actuator 40 may be configured and sized appropriately such that the clearance between the second actuator 40 and the elongate member 12 through the passage 18 is minimal, allowing the second actuator 40 to press or move the hemostatic agent 50 through the passage 18 of the elongate member 12.

As shown in Figure 11, the basic operation of the closure device 200 may be similar to the basic operation previously discussed with closure device 10. However, in this embodiment after the closure element 100 is secured in the deployed configuration about the proximal lumen wall 34, the second actuator 40 will then be positioned to press the hemostatic agent 50 out of the elongate member 12. Specifically, once the closure

element 100 is in the deployed configuration, the elongate member 12 may be moved in the proximal direction and the second actuator 40 may be pressed in the distal direction such that the hemostatic agent 50 is forced out of the elongate member 12 and onto the surface of the deployed closure element 100, and thus the hemostatic agent may be deposited onto the portion of the proximal lumen wall 34 that is in the general area of the deployed closure element 100.

The hemostatic agent 50 may be any material configured to aid in the healing of the body lumen wall as well as to cause the cessation of bleeding. Moreover, the hemostatic agent 50 may contain any material or agent that may be used to avoid infection. Suitable hemostatic materials for any of the embodiments described above may include chitosan, collagen, thrombin, PEG or other biocompatible materials. In one embodiment, chitosan may be utilized. The chitosan hemostatic composition may provide a strong clotting action to seal a hole, puncture, incision, or any other bleeding site to promote enhanced healing of the bleeding site and reduce opportunities for infection. Additionally, the chitosan hemostatic composition can be configured to swell in the presence of blood to form a hemostatic barrier that covers or otherwise plugs the bleeding site.

Chitosan is a polycationic polymer derived from chitin, which can also be used as described herein. Chitosan has a positive charge from primary amine groups that can interact with the negative charge of the lipids present on cell surfaces, such as blood cells. This electrostatic interaction has been identified as an aspect of the hemostatic properties of chitosan. Dry chitosan compositions can have increased hemostatic properties by increasing surface area, and thereby the contact area with blood. Processing methods, such as freeze drying, puffing, foaming, sponging, ballooning, combinations thereof, or the like, can be used to provide a porous, open cellular, or closed cellular structure with increased surface area. In addition to chitosan and/or chitin, other polymers having N-acetylglucosamines and N-glucosamines, such as poly-beta-1→4-N-acetylglucosamines with or without one or more monosaccharides being deacetylated and poly-beta-1→4-N-glucosamines, and derivatives thereof.

The chitosan or other similar polymer used in various embodiments of the present invention may be purified to facilitate use in a medical device and or used within the body of a subject. This may include being purified to remove proteins, other organic or inorganic contaminants. Such purification and processing of chitosan is well known in the art. Accordingly, the chitosan or other similar polymer can be considered to be

biocompatible, immunoneutral, and/or generally recognized as safe for use with or within a subject, such as a human or other animal.

Once the hemostatic agent 50 has been deployed next to the deployed closure element 100, the elongate member 12 along with the associated actuator 22 and second
5 actuator 40 may be removed from the patient.

The closure device discussed with the various example embodiments of the present invention may include various other configurations. For example, any configuration of the closure device that includes a closure element that is able to anchor
10 on the inside surface of the body lumen wall as well as on the outside surface of the body lumen wall (i.e. sandwich the wall of the body lumen between two closure elements or two closure element portions) may be used with the closure device contemplated with the present invention.

Accordingly, the previous figures and the corresponding text provide a number of different components and systems that may be used to close an opening in a body lumen.
15 In addition to the foregoing, other example embodiments may also be described in terms of flowcharts comprising one or more acts in a method for accomplishing a particular result. For example, Figure 12 illustrates a method 600 of closing an opening in tissue. The acts of method 600 are discussed more fully below with respect to the disclosures of Figures 1 through 11.

For example, Figure 12 shows that a method in accordance with an example
20 implementation of the invention may include inserting 602 a closure device into an opening in a body lumen wall. Inserting a closure device may involve inserting a closure device into an opening formed in tissue, the closure device including a delivery tube, an actuator, and a closure element, the closure element defined by a body having a proximal portion, a distal portion and a waist. For example, as shown in Figure 3, the closure
25 element 100 may be inserted through the proximal lumen wall 34.

After the closure device is inserted into an opening, a force may be applied 604 to the actuator to move a first portion of a closure element from a first configuration to a second configuration. Applying a force may involve applying a force to the actuator to
30 move the distal portion of the closure element from a first configuration toward a second configuration, wherein in the second configuration, portions of the closure element protrude from the body. For example, as shown in Figure 3, the actuator 22 may be moved in a proximal direction (as indicated by the arrow) such that the portions of the body member 102 located in-between the distal slits 112 are forced to collapse, bend,

and/or buckle and extend in an outward direction thus causing the distal portion of the closure element 100 to change from a delivery configuration to a deployed configuration.

Next, a second force may be applied 606 to an actuator to move a second portion of the closure element from a first configuration towards a second configuration.

5 Applying a second force may involve applying a second force to the actuator to move the proximal portion of the closure element from a first configuration toward a second configuration. For example, and as illustrated in Figure 5, the actuator 22 may be moved in a proximal direction, thus causing the portions of the body member 102 in-between the proximal slits 110 to collapse and extend outwardly.

10 Figures 13A through 13G illustrate an example embodiment of a closure device that uses a handle assembly 400. In particular, Figure 13A illustrates a closure device that includes a handle assembly 400 that has a handle element 402 and a hub member 404. The handle element 402 has a proximal end 406, a distal end 408, a grip portion 410, and an extended portion 412. Projections 414 may extend from the extended portion
15 412. Moreover, the handle element 402 includes a port 416 through which an actuator 22 may extend.

The handle element 402 is operatively associated with a hub member 404. The hub member 404 includes a hub body 418 that has a proximal end 420 and a distal end 422. A channel 424 is formed within the hub body 418 of the hub member 404, the
20 channel 424 configured to cooperate with the projections 414 located on the handle element 402. An elongate member 12 may be connected to the hub member 404. The elongate member 12 may be configured such that an actuator 22 may extend through the elongate member 12. Attached to a distal end of the actuator 22 is a closure element 100, as illustrated in Figure 13A.

25 Briefly, in operation, the handle assembly 400 assists a user in deploying the closure element 100 within an opening in a body lumen. For example, after the closure element 100 is positioned appropriately within the opening in the body lumen, as discussed above, the user may turn the handle element 402, which in turn assists to deploy the closure element 100. Specifically, the handle element 402 may be coupled to
30 the actuator 22 such that as the handle element 402 is rotated, the actuator applies a force upon the closure element 100 that causes the closure element 100 to change from a delivery configuration to a deployed configuration, as discussed above.

The handle assembly 400, shown in Figure 13A, may vary from one embodiment to the next. For example, the handle element 402 is one example aspect of the handle

assembly 400 that may vary. Figure 13B shows a bottom view of the handle element 402. The bottom view of the handle element 402 illustrates the grip portion 410, the extended portion 412, and the projections 414 that extend from or project out from the extended portion 412. Moreover, Figure 13B illustrates the port 416 through which the actuator 22
5 may extend.

The geometric configuration is one way in which the handle element 402 may vary. As illustrated in Figure 13B, the geometric configuration of the handle element 402 may have a substantially circular cross-sectional configuration. However, in other example embodiments, the cross-sectional configuration of the handle element including
10 the extended portion 412 and the grip portion 410 may have various other geometric configurations such as square, rectangle, triangle or any other configuration or combination of configurations.

Moreover, and as shown in Figure 13A and 13D, the handle element 402 may include a set screw 428. The set screw 428 may be positioned in the grip portion 410
15 such that a set screw may be used to secure the position of the actuator 22. Figure 13D illustrates how the set screw 428 may be positioned such to enter from the side of the grip portion 410 and into the port 416, and thus, secure the actuator 22.

Another way in which the handle element 402 may vary is the characteristics of the projections 414. As shown in Figure 13D, the projections 414 may be made from a
20 different piece of material than the extended portion 412. In alternate embodiments, the projections 414 may be manufactured out of the same piece of material as the extended portion 412.

Not only can the manufacture method vary with respect to the projections 414, but the location of the projections 414 on the extended portion 412 may vary from one
25 embodiment to the next. As illustrated in Figures 13A and 13D, the projections 414 may be located on the distal end 408 of the handle element 402. However, in alternative embodiments, the projections 414 may be located at various other locations or almost any location on the extended portion 412.

Another aspect of the handle element 402 that may vary from one embodiment to
30 the next is the grip portion 410. The grip portion 410 may be sized such that a human finger or a human hand would be able to easily turn and twist the grip portion 410. In order to help with the twisting of the handle element 402, the grip portion 410 may include a friction provider such as a piece of rubber or a pattern within the sidewall of the

grip portion to aid in helping a human hand grip the grip portion 410 and turn the handle element 402.

In addition to various geometric characteristics, the handle element 402 may vary in material composition. For example, in one example embodiment the handle element
5 402 may be made from a metal such as stainless steel. Other materials may be used to make the handle element 402 such as plastics, ceramics or any other material that would have structurally suitable properties.

Just as the handle element 402 may vary from one embodiment to the next, so too may the hub member 404. For example, the cross-sectional configuration of the hub
10 member 404 may vary from one embodiment to the next. The hub member, as illustrated in Figure 13A, has a substantially circular cross-sectional geometric configuration. Alternatively, in other example embodiments, the hub member 404 may have a cross-sectional geometric configuration that is square, rectangular, hexagonal, or any other configuration or combination of configurations.

Notwithstanding the cross-sectional configuration of the hub member 404, the
15 way in which the channel 424 is located throughout the hub member 404 may vary. For example, and as illustrated in Figure 13A, the channel 424 is configured such that the handle element 402 is allowed to rotate one full turn within the hub member 404. Alternatively, the channel 424 may be configured to allow more or less rotation of the
20 handle element 402. In one example embodiment, the channel 424 may only allow for a half turn of the handle element 402. Alternatively, in other embodiments of the invention, the channel 424 may allow for multiple rotations of the handle element 402.

In addition to the number of rotations in which the channel 424 allows the handle
element 402 to make, the channel 424 may also be configured with various pathways.
25 For example, and as illustrated in Figure 13A, the pathway of the channel 424 is relatively smooth from the bottom portion of the channel 424 around to the top portion of the channel 424. However, in alternative embodiments, the channel 424 may have step sections such that the projections 414 on the handle element 402 move within the channel at various steps from one depth to the next. In another example embodiment, the channel
30 424 may direct the handle element 402 to move with a combination of relatively smooth movements and stepped movements.

The operation of the handle assembly 400 will be discussed in further detail with reference to Figures 13C through 13G. The handle element 402 is inserted within a receiving area 426 located within the hub member 404, as illustrated in Figure 13D. The

projections 414 located on the extended portion 412 of the handle element 402 interact with the channel 424 on the hub member 404 such that as the handle element 402 is turned, the position of the handle element relative to the hub member 404 changes.

For example, and as illustrated in Figure 13C, the handle element 402 is located
5 towards the distal end of the hub member 404. When the handle element 402 is rotated, the projections 414 follow the channels 424 such that the handle element 402 moves in the proximal direction with respect to the hub member 404, as illustrated in more detail in Figures 13E and 13F. Moreover, if the actuator 22 is secured to the handle element 402 by way of the set screw 428, then as the handle element 402 moves in the proximal
10 direction with respect to hub member 404, the handle element 402 also pulls the actuator 22 in the proximal direction. Thus, as the handle element 402 is rotated, the actuator 22 is pulled in a proximal direction and the closure element 100 may be deployed, as previously described with relation to Figures 3 through 6.

In one specific embodiment, the closure element 100 with the handle assembly
15 400 cooperates with an introducer sheath 500, as illustrated in Figure 13G. The introducer sheath 500 may include an introducer elongate member 502. The elongate member 12 and the closure element 100 are passed through the introducer sheath 500 and extend through the introducer elongate member 502 such that the closure element 100 protrudes from the distal end of the introducer elongate member 502. In one example
20 embodiment, the closure element 100 has the distal slits protruding from the introducer elongate member 502.

In operation, the introducer sheath 500 may already be positioned such that the
introducer elongate member 502 is located at least partially within the body lumen or extended through an opening in a body lumen wall. The closure element 100, along with
25 the elongate member 12, may then be introduced into the introducer sheath 500 and positioned within the opening in the body lumen. With the closure device located within the introducer sheath 500, the handle element 402 may be rotated such that the actuator 22 is pulled in the proximal direction and the lower or distal region of the closure element 100 changes from a delivery configuration to a deployed configuration, as shown in
30 Figure 13E.

After the first portion of the closure element has been deployed, the introducer sheath 500 and the introducer elongate member 502 may be moved in the proximal direction such as to uncover the proximal slits 110. At this point, the handle element 402 may be again twisted or rotated such that the actuator 22 is moved or pulled in the

proximal direction, thus deploying the upper portion of the closure element 100, as shown in Figure 13F.

The amount of rotation that may be needed to deploy the closure element 100 or change the closure element 100 from a delivery configuration to a deployed configuration
5 may vary. In one example embodiment, the handle element 402 may be turned one half of a turn to deploy the first portion of the closure element 100 and then turned another half of a turn to deploy the second portion of the closure element 100. However, in other example embodiments it is understood that larger or smaller rotation may be used to deploy the closure element 100.

10 Once the closure element 100 is deployed and in place within the body lumen wall, the remainder of the closure device and the introducer sheath can be removed in a similar manner as described with respect to Figures 3-6.

Reference is now made to Figure 14, which illustrates an example closure element 300. The closure element 300 may include a proximal flange 302 and a distal flange 304.
15 The proximal flange 302 may include a first coupler 306 while the distal flange 304 may include a second coupler 308. In at least one example embodiment, the second coupler 308 may include friction elements 310, as illustrated in Figure 14. In further embodiments, the first coupler 306 and second coupler 308 may be configured to couple together in any of a variety of configurations, such as by friction, threading, snap-fit,
20 tongue-and-groove, similar coupling configurations, or combinations thereof. In a yet further embodiment, once the second coupler 308 is inserted into the first coupler 306, a pin or other elongate member may be inserted through the second coupler 308 to force the second coupler 308 outward and into more secure contact with the first coupler 306.

Briefly, in operation, the closure element 300 may be inserted into an opening in a
25 body lumen in a delivery configuration. The distal flange 304 may then be deployed within the body lumen and the proximal flange 302 may be deployed outside the body lumen. The proximal flange 302 and the distal flange 304 may then be coupled or otherwise joined together through the opening in the body lumen. In one example, the second coupler 308 is pressed into the first coupler 306 and locked into place with friction
30 elements 310 that allow the second coupler 308 to be pressed into the first coupler 306 but do not allow the second coupler 308 to be released from the first coupler 306.

The closure element 300, illustrated in Figure 14, may have various characteristics and configurations. For example, one way in which the closure element 300 may vary is the type of material used to make the closure element 300. In one embodiment the

closure element 300 may be manufactured from a bioabsorbable, bioresorbable, bioerodible, or biodegradable material. Examples of suitable materials for use are metals, metal alloys, polymers, or combinations thereof that decompose or biodegrade in a biological environment such as within a body lumen. For example, and not by limitation, suitable bioabsorbable materials may include magnesium, zinc, iron, silicon, zinc titanium, magnesium lithium, polyglycolic acid (PGA), polyhydroxybutyric acid, polyL-Lactic acid (PLLA), poly dl-lactic acid (PDLLA), polydilactidel glycolide acid, polydilactid acid, PolyDL Lactide-co-glycolide, Polylactic acid, Polyhydroxyalkanoates, polylactic acid-co-caprolactone, polylactic acid-co-Chitosan, poly-phosphazenes, poly-anhydrides, degradable poly-urethanes, biodegradable poly-carbonates, biodegradable ceramics such as those based on tricalcium phosphate or hydroxyapatite, analogous materials, co-polymers thereof, derivatives thereof, and any combinations thereof.

In addition to the various types of materials that may be used to manufacture the closure element 300, the closure element 300 may include additional material properties that may be useful. For example, the closure element 300 may be covered with a flexible membrane to aid in sealing the opening. The flexible membrane may be formed of a flexible bio-compatible or bioabsorbable material such as any of those that are described above. Moreover, the closure element 300 may further include a beneficial agent either disposed thereon as a coating or integrally formed within the material of the closure element 300. The beneficial agent may be configured to aid in healing and/or reduce the potential for infection.

Moreover, the closure element 300 may include additional elements to help a user place the closure element 300 within a body lumen. For example, the closure component 300 may further include a radiopaque marker or radiopaque coating in order to aid the user in positioning the closure element 300 within the puncture site of the body lumen. The radiopaque marker may be formed within the wall of the body of the first or second flange 302, 304 in the form of a rivet. In a further embodiment, a radiopaque coating may be disposed on the closure element 300 as a thin coating of radiopaque metal such as gold, tantalum, platinum, iridium, similar metals, or combinations thereof. In a yet further embodiment, the radiopaque coating may comprise an iodine contained polymer such as polytyrosine carbonate with iodine.

In addition to material aspects of the closure element 300, the configuration of the closure device 300 may vary from one embodiment to the next. For example, the cross-sectional configuration of the proximal and distal flanges 302 and 304 may vary from one

embodiment to the next. In one example embodiment, the proximal and distal flanges 302 and 304 may have a substantially circular or disc-like shape/configuration, as illustrated in Figure 14. In other examples, the proximal and distal flanges 302 and 304 may have various other shapes or configurations, such as square, rectangular, oval, or any
5 other cross-sectional configuration. Moreover, the proximal flange 302 and the distal flange 304 may have differing shapes or configurations. In a yet further embodiment, the proximal flange 302 and the distal flange 304 may be rotationally offset with respect to each other.

Just as the shape and configuration of the proximal flange 302 and the distal
10 flange 304 may vary, so too may the cross-sectional profile vary from one embodiment to the next. As illustrated in Figure 14, the proximal flange 302 and the distal flange 304 have a T-shaped cross-sectional profile with a substantially flat horizontal cross-bar section. In other example embodiments, the cross-bar section may further include ridges or protrusions that may be used to grip tissue and further anchor the closure element 300
15 within an opening in a body lumen.

Moreover, the second coupler 308 and first coupler 306 may have any configuration for joining or coupling the proximal flange 302 and the distal flange 304 together. For example, in one embodiment, the first coupler 306 and second coupler 308 may couple together through a hook and anchor configuration. In a further embodiment,
20 the first coupler 306 and second coupler 308 may have corresponding internal and external threads and may screw together. In a yet further embodiment, the first coupler 306 and second coupler 308 may have any other configuration that could be used to join or couple the proximal flange 302 to the distal flange 304. Moreover, in other example embodiments, the proximal flange 302 and the distal flange 304 may be made from the
25 same piece of material or permanently joined together prior to deployment.

Figure 15 illustrates an isolated view of an example distal flange 304. As illustrated in Figure 15, the distal flange 304 may have a distal end 304A and a proximal end 304B. Moreover, the distal flange 304 may include a second coupler 308 with a plurality of friction elements 310 located on the second coupler 308. In one example
30 embodiment, the distal flange 304 may further include a pull cord 312. The distal flange 304 may vary from one embodiment to the next. For example, the friction elements 310 may vary from one embodiment to the next. In one example embodiment, illustrated in Figure 15, the friction elements 310 may be equally spaced and arranged on the second coupler 308. In a further example embodiment, the friction elements 310 may be

randomly arranged. Moreover, in other embodiments, there may be only one friction element 310 instead of a plurality of friction elements 310.

Another way in which the friction elements 310 may vary is the type of friction elements 310 used. For example, the friction elements 310 in one example embodiment
5 may be o-ring type structures that are configured to have a tolerance fit with the first coupler 306 of the proximal flange 302. In another example, the friction elements 310 may include teeth or ramps which could be complimentary to teeth or ramps disposed within the first coupler 306, thereby, causing the proximal flange 302 and the distal flange 304 to be locked together.

10 Figure 16 illustrates an isolated view of an example of the proximal flange 302. The proximal flange 302 may include a proximal end 302a, a distal end 302b and a first coupler 306 that includes a passage 314. The proximal flange 302 may vary from one embodiment to the next. For example, the passage 314 in the first coupler 306 may vary. As illustrated in Figure 16, the passage 314 may have a constant cross-sectional
15 dimension. In other example embodiments, the cross-sectional dimension of the passage 314 may vary. For example, the cross-sectional dimension may become smaller moving from the distal end 302b to the proximal end 302a of the proximal flange 302. In this way, the second coupler 308 on the distal flange 304 may be configured to wedge or otherwise interface with the narrowing passage 314.

20 The material of the proximal flange 302 and the distal flange 304 may vary from one embodiment to the next. The proximal flange 302 and the distal flange 304 may be generally constructed of a flexible biocompatible material, such as a bioabsorbable material. Examples of suitable materials are described in more detail above.

25 Figures 17 through 18B illustrate example embodiments of a closure device 330 that employs the closure element 300. As shown in Figure 17, the proximal flange 302 and the distal flange 304 may be configured such that they are able to collapse, bend, or flex at approximately right angles with respect to the first coupler 306 and second coupler 308 respectively, thus forming a delivery configuration. While in the delivery configuration, the proximal flange 302 and the distal flange 304 may be inserted within a
30 delivery tube 316. The delivery tube 316 may have a passage 332 that has a cross-sectional dimension that allows the proximal flange 302 and the distal flange 304 to be inserted within the passage 332. Moreover, the closure device may include a first pusher 318 and a second pusher 320, with the first pusher 318 operatively associated with the

distal flange 304, and the second pusher 320 operatively associated with the proximal flange 302.

The configuration of the closure device 330 may vary from one embodiment to the next. For example, and as illustrated in Figure 17, the first pusher 318 may be configured to extend through the passage 314 of the proximal flange 302 and interface with or otherwise apply a force to the distal flange 304. The second pusher 320 may be configured with a larger cross-sectional dimension such that it cannot pass through the passage 314 of the proximal flange 302, and thus, the second pusher 320 can interface with or otherwise apply a force to the proximal flange 302.

While positioned within the delivery tube 316, the proximal flange 302 and the distal flange 304 may be uncoupled together. When the proximal and distal flanges 302 and 304 are not connected, the first and second pushers 318 and 320 can move the proximal flange 302 and distal flange 304 independent from one another to advance or retract the proximal flange 302 and/or distal flange 304. In further embodiments, the proximal flange 302 and the distal flange 304 may be coupled together during the delivery of the closure element 300 within the opening in the body lumen. When the proximal and distal flanges are coupled together while in the delivery tube 316, a single pusher may be used and there may not be a need for a first and second pusher. For example, the second pusher 320 alone may move and control both the proximal and distal flanges 302 and 304.

Figures 18A and 18B illustrate an example implementation of the closure device 330. In particular, Figure 18A illustrates the deployed configuration of the distal flange 304 within the body lumen. In order to deploy the distal flange 304, delivery tube 316 is inserted into an opening located in the body lumen wall 322. At that point, the first pusher 318 may apply a force in the distal direction on the distal flange 304. Once the distal flange 304 leaves or exits the delivery tube 316, the distal flange 304 may elastically or otherwise move from the u-shape configuration or delivery configuration into a deployed configuration, as shown in Figure 18A.

Once deployed, the distal flange 304 may then be attached or coupled to the proximal flange 302, if not already coupled. In one example embodiment, this attachment may occur by way of the pull-cord 312. For example, a user of the closure device 330 may pull the pull-cord 312 in a proximal direction, thus pulling the distal flange 304 relative to and towards the proximal flange 302. In this way, the second coupler 308 located on the distal flange 304 may be pulled into the first coupler 306 located on the

proximal flange 302. In further embodiments, the deployment of the closure element 300 could still move forward at this point without having connected the proximal flange 302 to the distal flange 304. In further embodiments, the pull-cord 312 can be coupled to an automated and/or powered tensioning device configured to provide a desired tension to the pull-cord 312. In yet further embodiments, the pull-cord 312 may be sufficiently rigid to transfer both distal and proximal forces to the closure element 300. In additional embodiments, the closure element 300 and any components thereof may be coupled to a closure system configured to deploy the closure element 300 upon manipulation of the closure system by a user.

The spacing between the proximal flange 302 and distal flange 304 is adjustable depending upon the amount of force applied to the distal flange 304 by the pull-cord 312 and depending on the thickness of the body lumen wall where the closure element 300 is being deployed, thereby enabling the closure element 300 to be adjusted for various anatomies. As will be described in greater detail below, a charge of hemostatic material may be disposed proximal to the deployed closure element 300, such as within the tissue tract and/or against the outer surface of the deployed proximal flange 302 and body lumen, to further enhance sealing.

Moving now to Figure 18B, the proximal flange 302 is shown in a deployed configuration outside of the delivery tube 316. In order for the proximal flange 302 to achieve the deployed configuration, the second pusher 320 may apply a force in the distal direction upon the proximal flange 302. While the second pusher 320 applies a force in the distal direction on the proximal flange 302, the delivery tube 316 may be pulled in the proximal direction such that the proximal flange 302 exits the delivery tube 316. Upon exiting the delivery tube 316, the proximal flange 302 may move elastically or otherwise from the delivery configuration to the deployed configuration such that the proximal flange 302 extends outward.

If the proximal flange 302 and the distal flange 304 have not yet been coupled together at this point, then the proximal flange 302 and the distal closure element may be pressed together such that the second coupler 308 located on the distal flange 304 may be pressed into the first coupler 306 located on the proximal flange 302. This may be done by use of a pull-cord 312, the first pusher 318, and/or second pusher 320, as discussed above. Once the proximal flange 302 and the distal flange 304 are coupled together and surround the lumen wall 322, the delivery tube 316 along with the first pusher 318 and

second pusher 320 may be removed from the patient, while the closure element 300 remains to at least partially occlude or block the opening in the body lumen wall 322.

The closure device discussed with the various example embodiments of the present invention may include various other configurations. For example, any
5 configuration of the closure device that includes a closure element that is able to anchor on the inside surface of the body lumen wall as well as on the outside surface of the body lumen wall (i.e. sandwich the wall of the body lumen between two portions of the closure element) may be used with the closure device.

As briefly mentioned above, the closure device 330 may include a hemostatic
10 agent. For example, the passage 332 may be at least partially filled with the hemostatic agent in the space between the proximal flange 302 and the distal flange 304 such that as the closure element 300 is deployed, the hemostatic agent may be deployed proximate the opening in the tissue.

The hemostatic agent may be any material that is known to aid in the healing of
15 the body lumen wall as well as to cause the cessation of bleeding. Moreover, the hemostatic agent may contain any material or agent that may be used to avoid infection. Suitable hemostatic materials for any of the embodiments described above may include chitosan, collagen, thrombin, PEG or other biocompatible materials. In one embodiment, chitosan may be utilized. The chitosan hemostatic composition can provide a strong
20 clotting action to seal a hole, puncture, incision, or any other bleeding site to promote enhanced healing of the bleeding site and reduce opportunities for infection. Additionally, the chitosan hemostatic composition can be configured to swell in the presence of blood to form a hemostatic barrier that covers or otherwise plugs the bleeding site and/or aids the hemostasis of the percutaneous tissue tract.

Chitosan is a polycationic polymer derived from chitin, which can also be used as
25 described herein. Chitosan has a positive charge from primary amine groups that can interact with the negative charge of the lipids present on cell surfaces, such as blood cells. This electrostatic interaction has been identified as an aspect of the hemostatic properties of chitosan. Dry chitosan compositions can have increased hemostatic properties by
30 increasing surface area, and thereby the contact area with blood. Processing methods, such as freeze drying, puffing, foaming, sponging, ballooning, combinations thereof, or the like, can be used to provide a porous, open cellular, or closed cellular structure with increased surface area. In addition to chitosan and/or chitin, other polymers having N-acetylglucosamines and N-glucosamines, such as poly-beta-1→4-N-acetylglucosamines

with or without one or more monosaccharides being deacetylated and poly-beta-1→4-N-glucosamines, and derivatives thereof.

The chitosan or other similar polymer used in various embodiments of the present invention may be purified to facilitate use in a medical device and or used within the body
5 of a subject. This may include being purified to remove proteins or other organic and/or inorganic contaminants. Such purification and processing of chitosan is well known in the art. Accordingly, the chitosan or other similar polymer can be considered to be biocompatible, immunoneutral, and/or generally recognized as safe for use with or within a subject, such as a human or other animal.

10 Accordingly, the previous figures and the corresponding text provide a number of different components and systems that may be used to close an opening in a body lumen. In addition to the foregoing, other example embodiments may also be described in terms of flowcharts comprising one or more acts in a method for accomplishing a particular result. For example, Figure 19 illustrates a method 700 of closing an opening in tissue.
15 The acts of method 700 are discussed more fully below with respect to the disclosures of Figures 14-18.

For example, Figure 19 shows that a method in accordance with an example implementation of the invention may include inserting 702 a closure device into an opening in a body lumen wall. Inserting a closure device may involve inserting a closure
20 device into an opening formed in tissue, the closure device including a delivery tube, an actuator, and a closure element, the closure element defined by a body having a proximal portion, a distal portion and a waist. For example, as shown in Figure 18A, the closure element 300 may be inserted through the proximal lumen wall 322 or through an introducer that has already been implanted/positioned through the lumen wall.

25 After the closure device is inserted into an opening, a force may be applied 704 to the actuator to move a first portion of a closure element from a first configuration to a second configuration. Applying a force may involve applying a force to the actuator to move the distal portion of the closure element from a first configuration toward a second configuration, wherein in the second configuration, portions of the closure element
30 protrude from the body. For example, as shown in Figure 18A, the pull cord 312 may be moved in a proximal direction (as indicated by the arrow), thus causing the distal flange 304 to change from a delivery configuration to a deployed configuration.

Next, a second force may be applied 706 to an actuator to move a second portion of the closure element from a first configuration towards a second configuration.

Applying a second force may involve applying a second force to the actuator to move the proximal portion of the closure element from a first configuration toward a second configuration. For example, and as illustrated in Figure 18B, the actuator second pusher 320 may be moved in a distal direction, thus causing the proximal flange 302 to change
5 from a delivery configuration to a deployed configuration.

After the closure element is fully deployed, the closure device may be disengaged from the closure element and removed from the patient.

The present disclosure may be embodied in other specific forms without departing from its spirit or essential characteristics. The described embodiments are to be
10 considered in all respects only as illustrative and not restrictive. The scope of the disclosure is, therefore, indicated by the appended claims rather than by the foregoing description. All changes which come within the meaning and range of equivalency of the claims are to be embraced within their scope. It shall be further understood that although the present disclosure has been described in relation to vessel closure, it is contemplated
15 that the closure component of the present invention may be utilized to close other openings in the body such as PFO openings, or openings formed in organs such as the stomach for certain surgical procedures, and/or for closing fistulae.

CLAIMS

What is claimed is:

- 5 1. A device for closing an opening in tissue, comprising:
 a body member having a proximal portion, a distal portion, and a waist
 portion located between the proximal portion and the distal portion, the proximal
 portion having a first proximal cross-sectional dimension and the distal portion
 having a first distal cross-sectional dimension;
- 10 a plurality of proximal slits disposed on the proximal portion of the body
 member, the proximal slits cooperating with the body member to change the first
 proximal cross-sectional dimension of the proximal portion to a second proximal
 cross-sectional dimension; and
- a plurality of distal slits disposed on the distal portion of the body member,
15 the distal slits cooperating with the body member to change the first distal cross-
 sectional dimension of the distal portion to a second distal cross-sectional
 dimension.
2. The device as recited in claim 1, wherein the first proximal cross-sectional
20 dimension is smaller than the second proximal cross-sectional dimension and the first
 distal cross-sectional dimension is smaller than the second distal cross-sectional
 dimension.
3. The device as recited in claim 2, further comprising an actuator operatively
25 associated with the body member to cause the first distal cross-sectional dimension to
 change to the second distal cross-sectional dimension and to cause the first proximal
 cross-sectional dimension to change to the second proximal cross-sectional dimension.
4. The device as recited in claim 3, wherein the actuator comprises:
30 a coupler element coupled to the distal portion of the body member; and
 a locking element that cooperates with the proximal portion of the body
 member to maintain the second proximal cross-sectional dimension and the
 second distal cross-sectional dimension by securing the body member between the
 locking element and the coupler element.

5. The device as recited in claim 1, wherein the body member is made from biocompatible, bioabsorbable, bioerodible, biodegradable, and/or bioresorbable material.

5 6. The device as recited in claim 3, further comprising:
a second actuator; and
a charge of hemostatic material, the second actuator operatively associated with the charge of hemostatic material such that the second actuator is able to deploy the charge of hemostatic material at or adjacent to the opening in the
10 tissue.

7. A device for closing an opening in a body lumen, comprising:
an elongate member having a proximal end, a distal end, and a passage extending from the proximal end toward the distal end;
15 a closure element having a proximal end, a distal end, and a waist portion, wherein the proximal end and the distal end are configured to move between a delivery configuration and a deployed configuration, and the waist portion has a constant configuration, and wherein the closure element is initially at least partially disposed within the passage of the elongate member with the proximal end and distal end being in the delivery configuration;
20 a first actuator operatively associated with the closure element and configured to deploy the closure element;
a second actuator operatively associated with a charge of hemostatic material and configured to deploy the charge of hemostatic material out of the
25 distal end of the elongate member.

8. The device as recited in claim 7, wherein the closure element further comprises a plurality of proximal slits and a plurality of distal slits.

30 9. The device as recited in claim 8, wherein the distal slits and the proximal slits work independently to permit the distal portion to move from the delivery configuration to the deployed configuration while the proximal portion remains in the delivery configuration.

10. The device as recited in claim 8, wherein the proximal slits and distal slits are substantially parallel with a longitudinal axis of the closure element.

11. The device as recited in claim 8, wherein the proximal slits and the distal
5 slits have a curved configuration.

12. A closure element with a delivery configuration and a deployed
configuration, the closure element being configured to close an opening in a wall of a
body lumen, the opening in the wall of the body lumen having an opening cross-sectional
10 dimension, the closure element comprising:

a first portion having a delivery configuration and a deployed
configuration, wherein the first portion is configured to pass through the opening
in the wall of the body lumen when in the delivery configuration and resist
passage through the opening in the wall of the body lumen when in the deployed
15 configuration;

a second portion having a delivery configuration and a deployed
configuration, wherein the second portion is configured to pass through the
opening in the wall of the body lumen when in the delivery configuration and
resist passage through the opening in the wall of the body lumen when in the
20 deployed configuration; and

a middle portion positioned between the first portion and the second
portion, the middle portion having a cross-sectional dimension substantially
similar to the opening cross-sectional dimension.

13. A closure element as recited in claim 12, wherein the closure element is
25 configured to close the opening in the wall of the body lumen by being deployed within
the opening with the distal portion positioned distal the opening in a deployed
configuration, the proximal portion positioned proximal the opening in a deployed
configuration, and the middle portion positioned at least partially within the opening.

14. A closure element as recited in claim 12, further comprising:
a first plurality of slits disposed within the first portion; and
a second plurality of slits disposed within the second portion.

5 15. A closure element as recited in claim 14, wherein the first plurality of slits
are offset from the second plurality of slits.

16. A closure element as recited in claim 14, wherein the first plurality of slits
or the second plurality of slits have a radius of curvature.

10

17. A closure element as recited in claim 12, further comprising an indentation
in the first portion or the second portion, wherein the first portion and second portion are
made from a tubular member, the indentation forming a wall thickness less than the wall
thickness of the remainder of the tubular member.

15

18. A method of closing an opening in tissue, comprising:
inserting a closure device at least partially through the opening, the closure
device including a delivery tube, an actuator, and a closure element, the closure
element comprising a body having a proximal portion, a distal portion, and a waist
portion;

20

applying a force to the actuator to move the distal portion of the closure
element from a first configuration toward a second configuration, wherein in the
second configuration, one or more extensions of the distal portion protrude from
the body;

25

applying a second force to the actuator to move the proximal portion of the
closure element from a first configuration toward a second configuration, wherein
in the second configuration, one or more extensions of the proximal portion
protrude from the body.

30

19. The method recited in claim 18, further comprising engaging the distal
portion of closure element with tissue adjacent the opening when the distal portion of the
closure element is in the second configuration.

20. The method recited in claim 18, further comprising locking the distal portion and the proximal portion of the closure element in their respective second configurations.

5 21. The method according to claim 18, further comprising deploying a hemostatic material on or adjacent to the opening in the tissue.

22. The method recited in claim 18, further comprising disengaging the delivery tube and actuator from the closure element and removing the delivery tube and
10 actuator.

23. A system for closing an opening in a body lumen, comprising:
a closure element having a delivery configuration and a deployed configuration;
15 an actuator coupled to the closure element; and
a handle assembly comprising:
a handle element; and
a hub member, wherein the handle element is rotatable within the
hub member, the handle element being operatively associated with the
20 actuator to move the closure element from the delivery configuration to the
deployed configuration upon rotation of the handle element.

24. The system as recited in claim 23, wherein the handle assembly further
comprises:
25 a protrusion extending from the handle element; and
a channel formed in the hub member, wherein the protrusion cooperates
with the channel to move the handle element and actuator longitudinally relative
to the hub member upon rotation of the handle element relative to the hub
member.

30 25. The system as recited in claim 23, the handle element further comprising a
set screw that secures the actuator to the handle element.

26. A device for closing an opening in a wall of a body lumen, comprising:
a closure element, comprising:
a first flange being movable between a delivery cross-sectional
dimension and a deployed cross-sectional dimension;
5 a second flange being movable between a delivery cross-sectional
dimension and a deployed cross-sectional dimension;
a first coupler element disposed on the first flange; and
a second coupler element disposed on the second flange, wherein
the first coupler element and the second coupler element are configured to
10 couple the first flange to the second flange.

27. The device as recited in claim 26, wherein the delivery cross-sectional
dimension of the first flange is smaller than the deployed cross-sectional dimension of the
first flange.

28. The device as recited in claim 27, wherein the delivery cross-sectional
dimension of the second flange is smaller than the deployed cross-sectional dimension of
the second flange.

29. The device as recited in claim 28, wherein the first coupler element further
includes friction elements that resist relative movement between the first coupled element
and the second coupler element.

30. The device as recited in claim 29, further comprising:
25 a first pusher that is operatively associated with the first flange to cause the
first flange to move from the delivery cross-sectional dimension to the deployed
cross-sectional dimension; and
a second pusher that is operatively associated with the second flange to
cause the second flange to move from the delivery cross-sectional dimension to
30 the deployed cross-sectional dimension.

31. The device as recited in claim 30, further comprising a delivery tube
configured to accept the closure element when the first flange and the second flange are

in their respective delivery cross-sectional dimensions and wherein the delivery tube is operatively associated with the first pusher and second pusher.

32. The device as recited in claim 31, further comprising a charge of
5 hemostatic material positioned within the delivery tube.

33. The device as recited in claim 26, wherein the first flange and the second
flange is made from a biocompatible material that is bioabsorbable, bioerodible,
10 biodegradable or bioresorbable.

34. A closure element for closing an opening in a body lumen, comprising:
a proximal flange with a first coupler element;
a distal flange with a second coupler element; and
a pull cord operatively associated with the distal flange to move the distal
15 flange relative the proximal flange and couple the second coupler element to the
first coupler element.

35. The closure element as recited in claim 34, wherein the proximal flange is
movable between a delivery configuration and a deployed configuration, wherein the
20 proximal flange has flange portions that are bent in the delivery configuration and are
substantially straight in the deployed configuration.

36. The closure element as recited in claim 34, wherein the distal flange is
movable between a delivery configuration and a deployed configuration, wherein the
25 distal flange has flange portions that are bent in the delivery configuration and are
substantially straight in the deployed configuration.

37. The closure element as recited in claim 34, wherein the second coupler
element includes one or more friction elements and wherein the first coupler element
30 includes a passage that cooperates with the friction elements to couple the proximal
flange to the distal flange.

38. The closure element as recited in claim 37, wherein the pull cord extends
through the passage in the first coupler element.

39. A closure element with a delivery configuration and a deployed configuration, the closure element configured to close an opening in a wall of a body lumen, the opening in the wall of the body lumen having an opening cross-sectional dimension, the closure element comprising:

5 a first flange having a delivery configuration and a deployed configuration, wherein the first flange is configured to pass through the opening in the wall of the body lumen when in the delivery configuration and resist passage through the opening in the wall of the body lumen when in the deployed configuration;

10 a second flange having a delivery configuration and a deployed configuration, wherein the second flange is configured to resist passage through the opening in the wall of the body lumen when in the deployed configuration; and

15 a coupler portion positioned between the first flange and the second flange having a cross-sectional dimension substantially similar to the opening cross-sectional dimension.

40. The closure element as recited in claim 39, wherein the closure element is configured to close the opening in the wall of the body lumen when the closure element is positioned with the body lumen between the first flange and the second flange in their
20 respective deployed configurations and with the coupler portion positioned at least partially within the opening.

41. The closure element as recited in claim 40, wherein the coupler portion further comprises:

25 a passage operatively associated with the first flange; and

 one or more friction elements operatively associated with the second flange and configured to resist relative movement between the first flange and second flange.

30 42. The closure element as recited in claim 41, wherein the one or more friction elements comprises a plurality of rings configured to create a slip fit with the passage.

43. The closure element as recited in claim 42, further comprising a pull cord that is coupled to the second flange and extends through the passage such that a user can apply a force to the pull cord to move the second flange relative to the first flange and couple the first flange to the second flange.

5

44. A method of closing an opening in tissue, comprising:

inserting a closure device at least partially through an opening formed in tissue, the closure device including a delivery tube, an actuator, and a closure element, the closure element defined by a body having a proximal portion, a distal portion and a waist;

10

applying a force to the actuator to move the distal portion of the closure element from a first configuration toward a second configuration;

applying a second force to the actuator to move the proximal portion of the closure element from a first configuration toward a second configuration.

15

45. The method recited in claim 44, further comprising engaging the distal portion of closure element with a distal surface of tissue adjacent the opening when the distal portion of the closure element is in the second configuration and prior to moving the proximal portion from a first configuration toward a second configuration.

20

46. The method according to claim 44, further comprising deploying a hemostatic material on or adjacent to the opening in the tissue.

47. The method recited in claim 44, further comprising disengaging the delivery tube and actuator from the closure element and removing the delivery tube and actuator from the opening in the tissue.

25

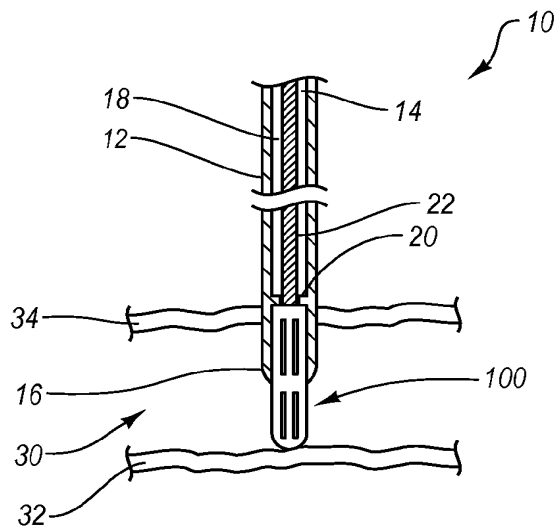

Fig. 1

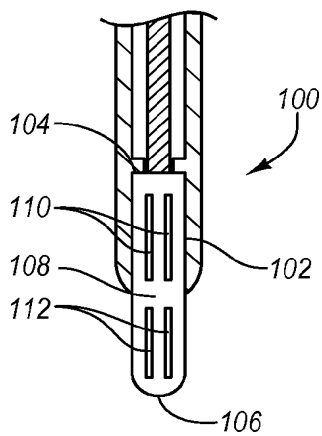

Fig. 2A

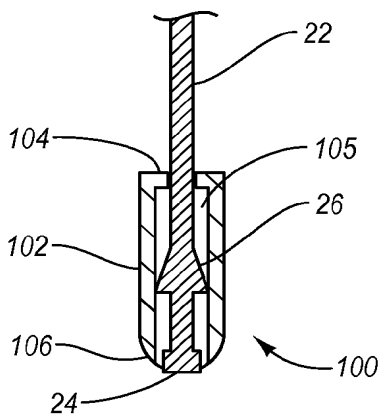

Fig. 2B

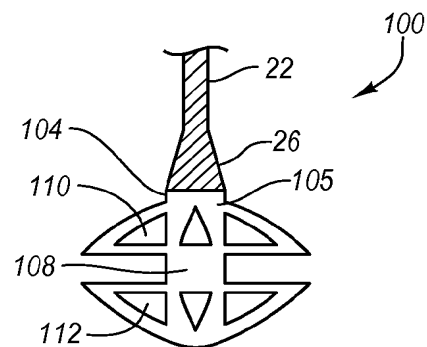

Fig. 2C

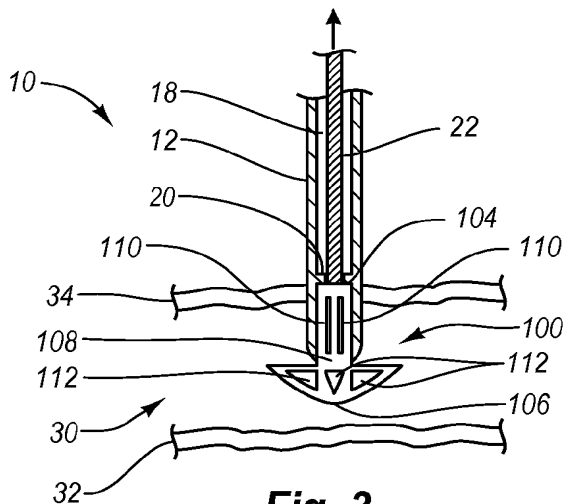

Fig. 3

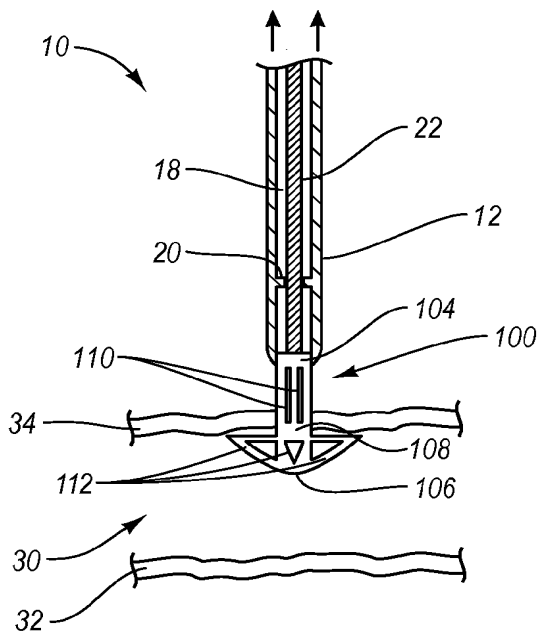

Fig. 4

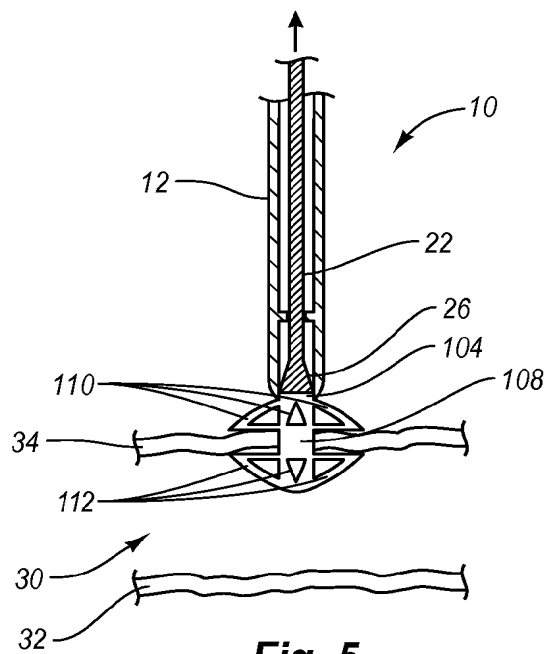

Fig. 5

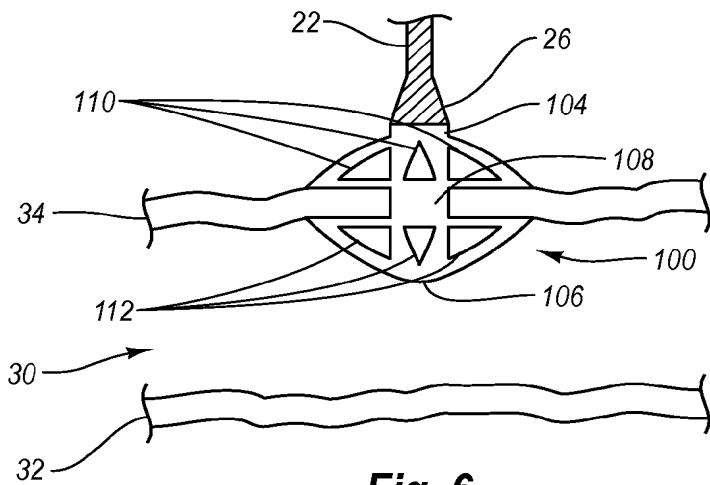

Fig. 6

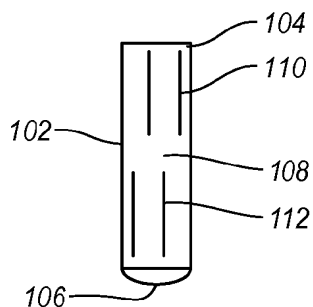

Fig. 7A

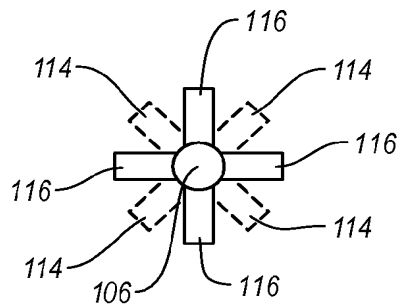

Fig. 7B

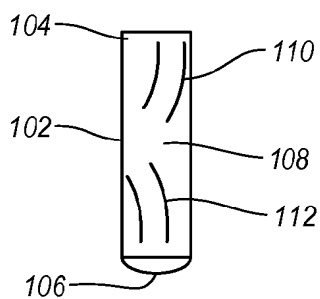

Fig. 8A

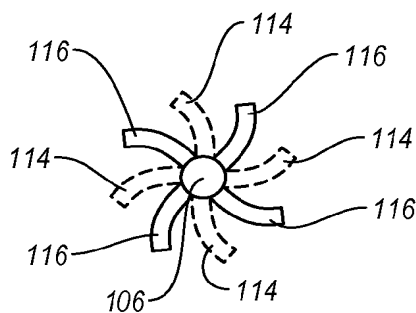

Fig. 8B

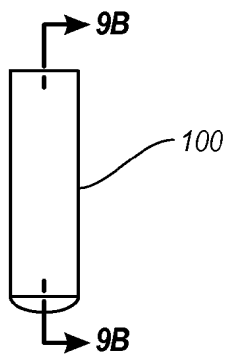

Fig. 9A

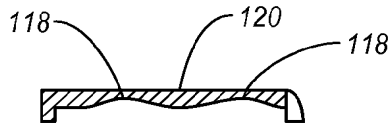

Fig. 9B

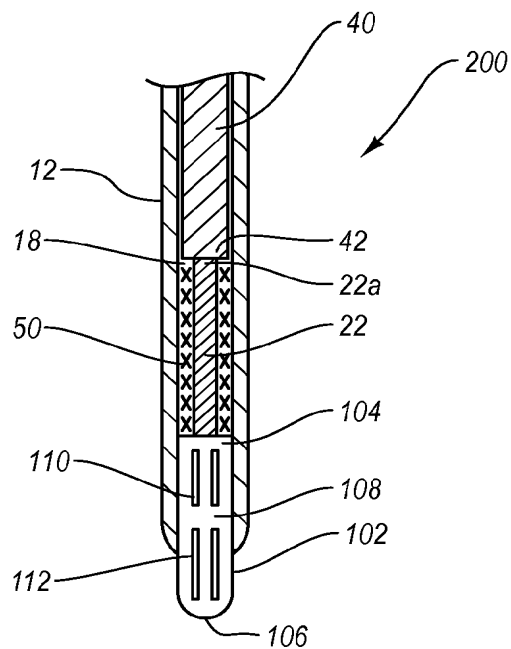

Fig. 10

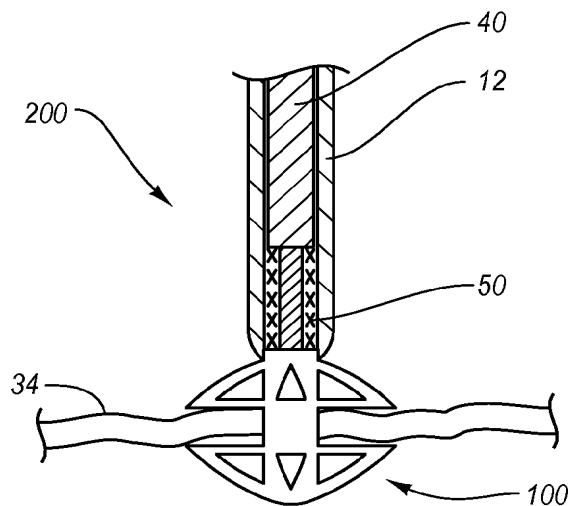
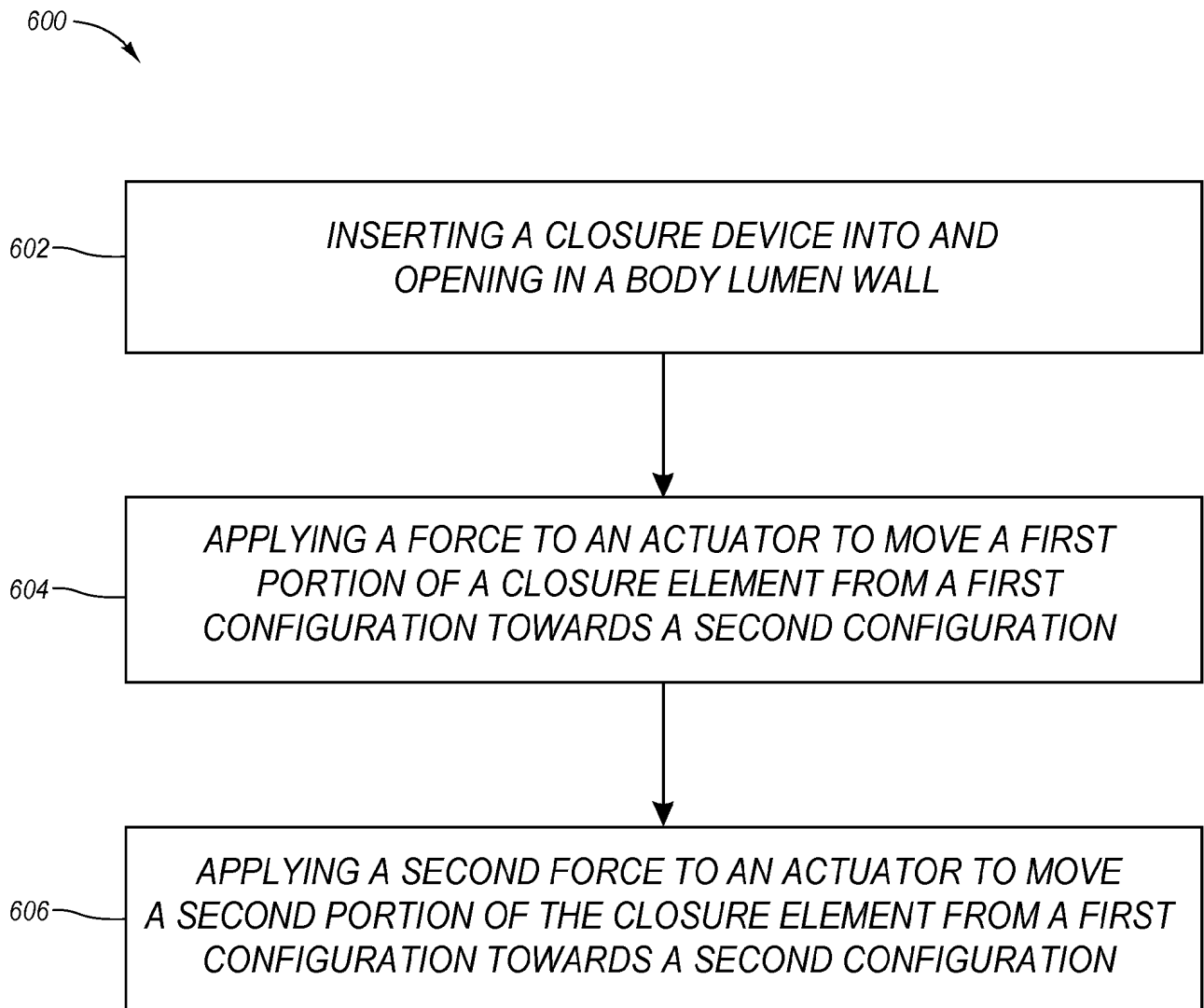

Fig. 11

**Fig. 12**

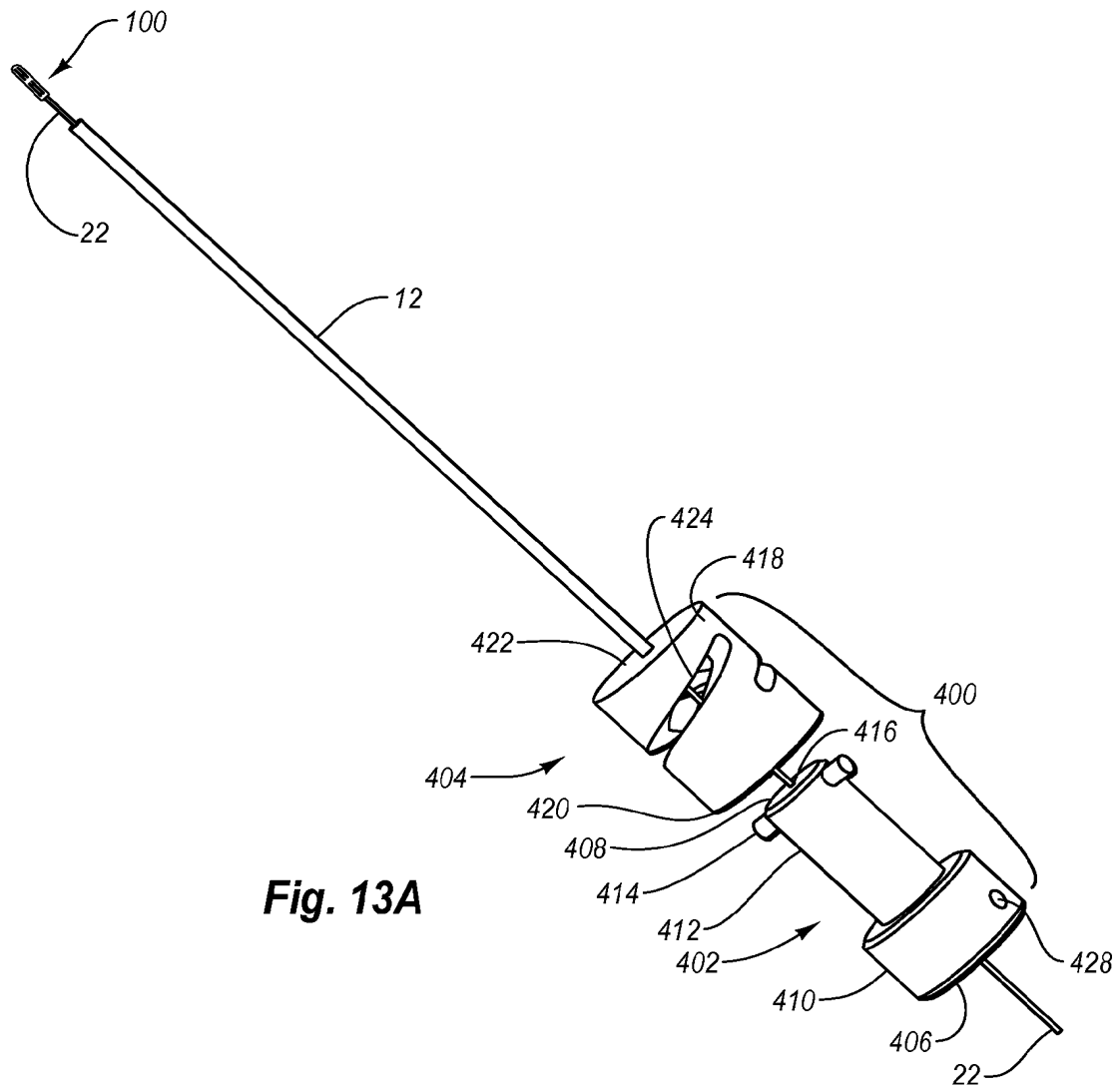

Fig. 13A

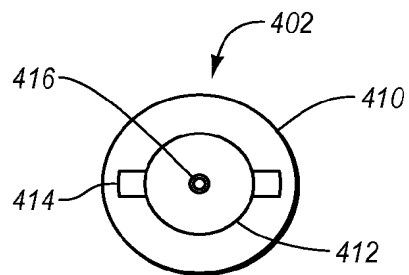
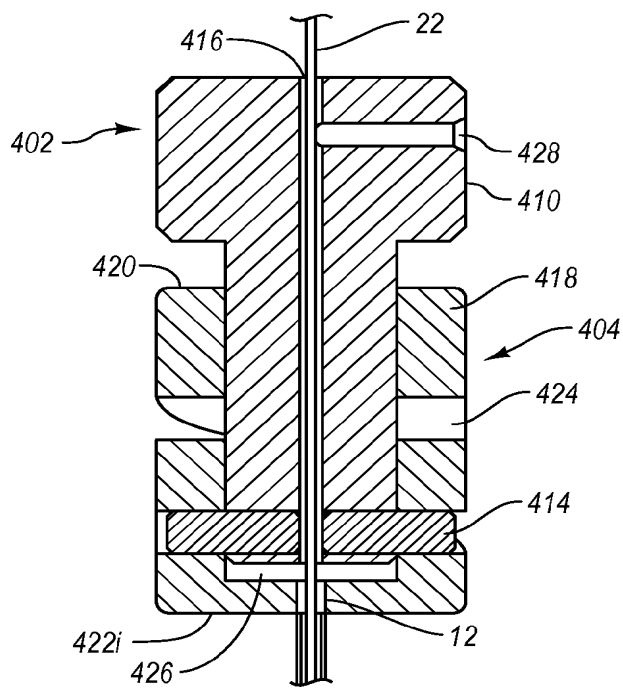
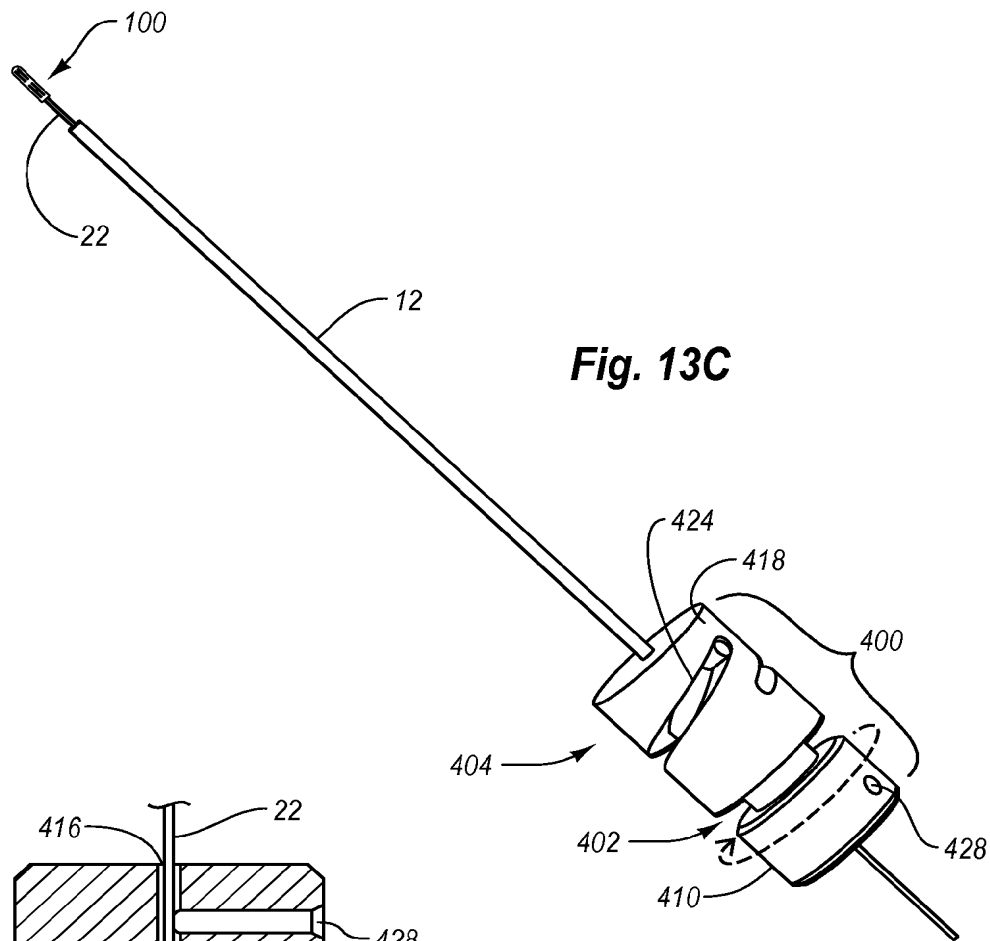

Fig. 13B



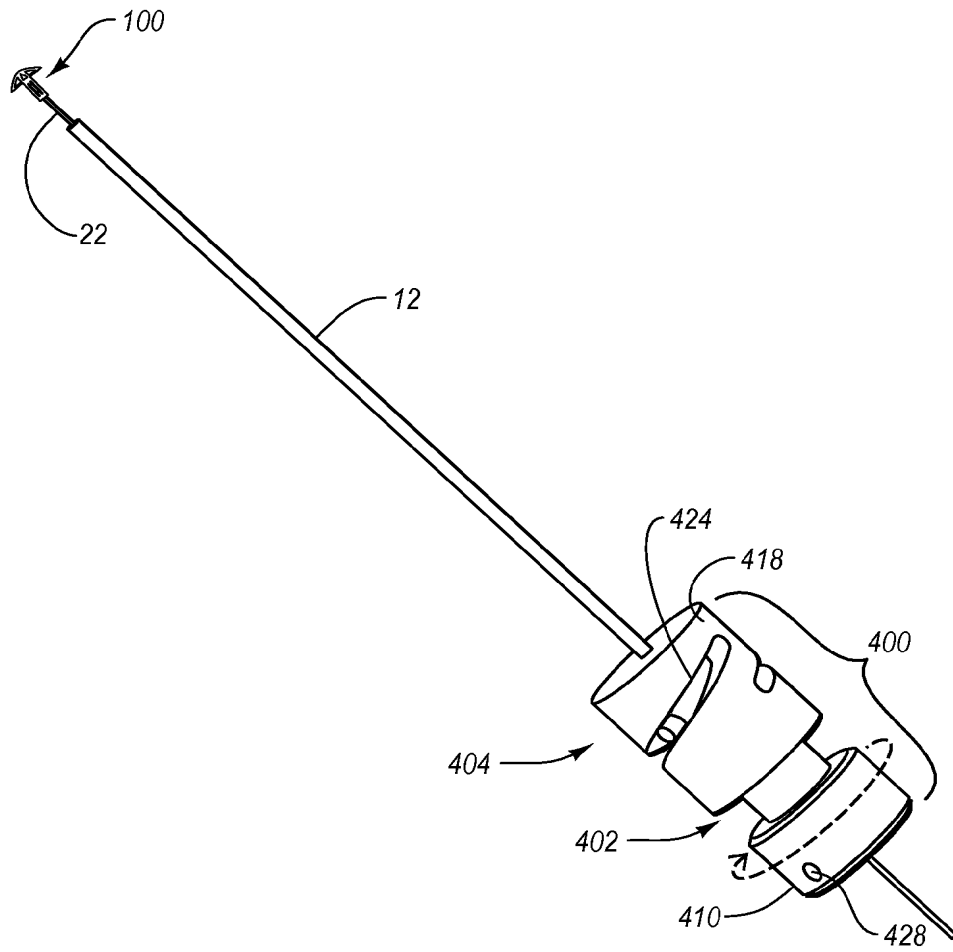

Fig. 13E

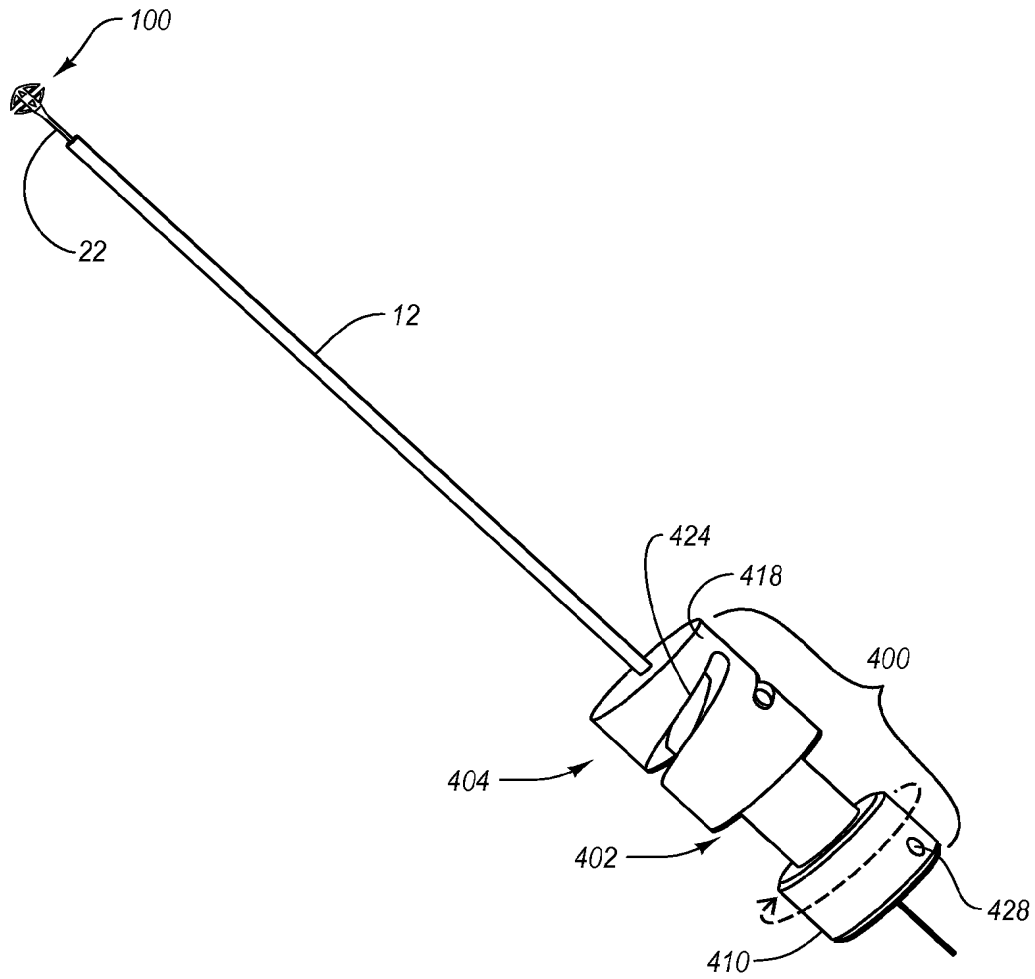

Fig. 13F

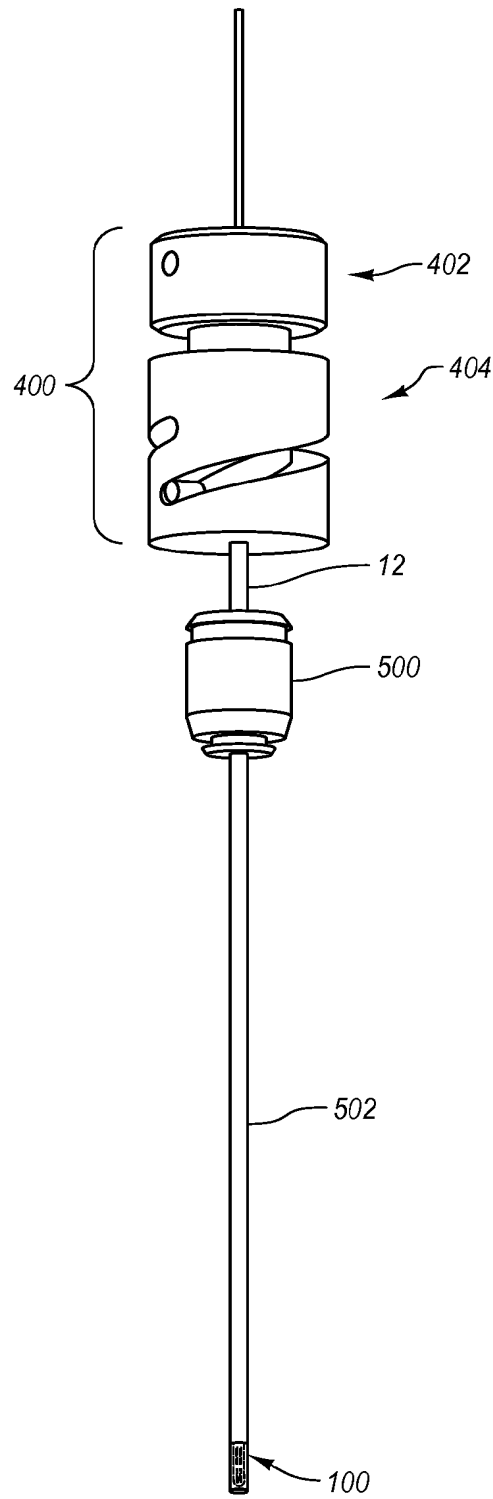

Fig. 13G

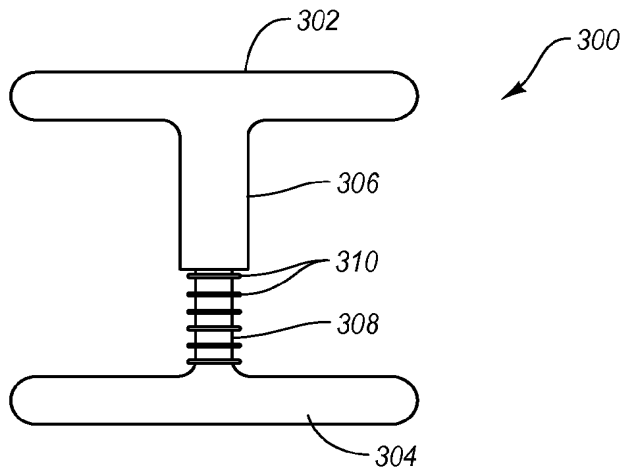

Fig. 14

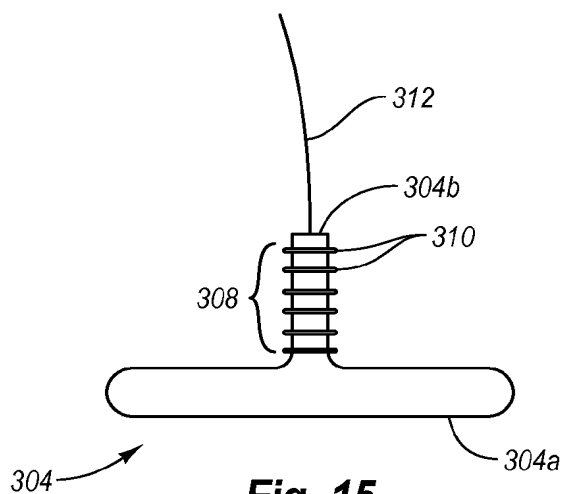

Fig. 15

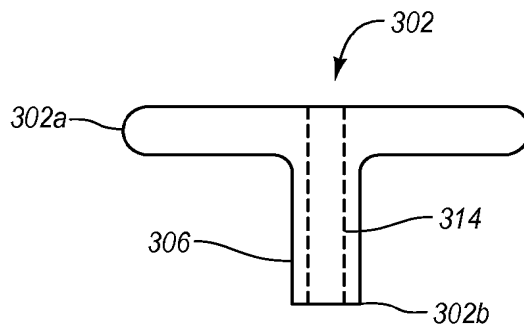

Fig. 16

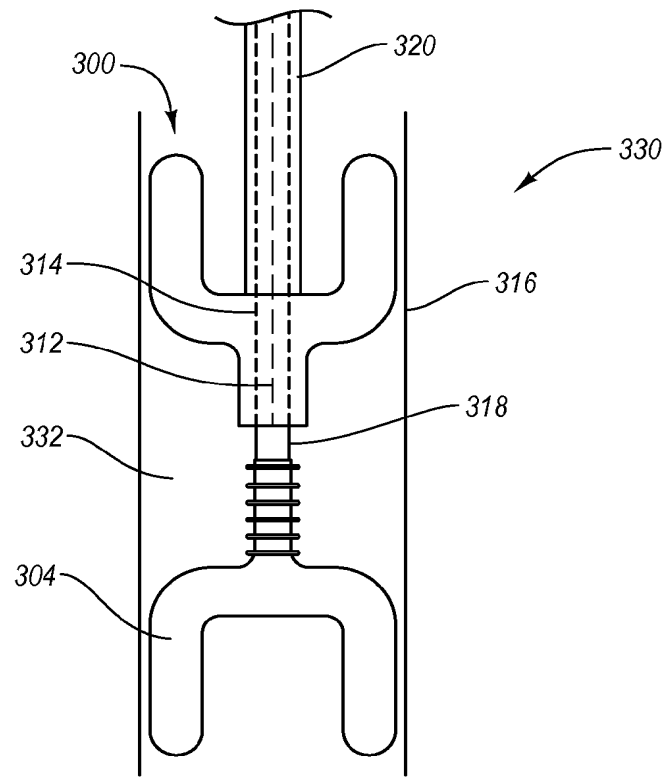

Fig. 17

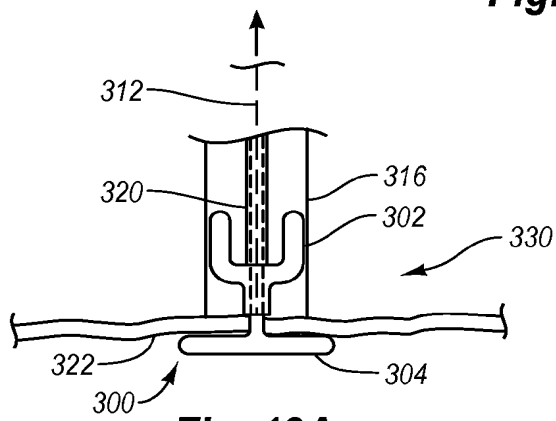

Fig. 18A

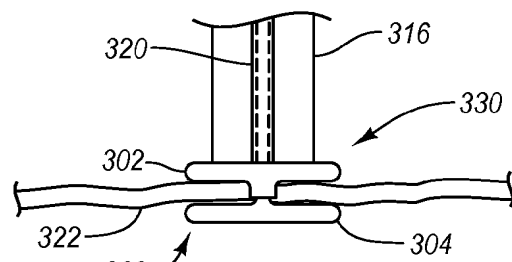
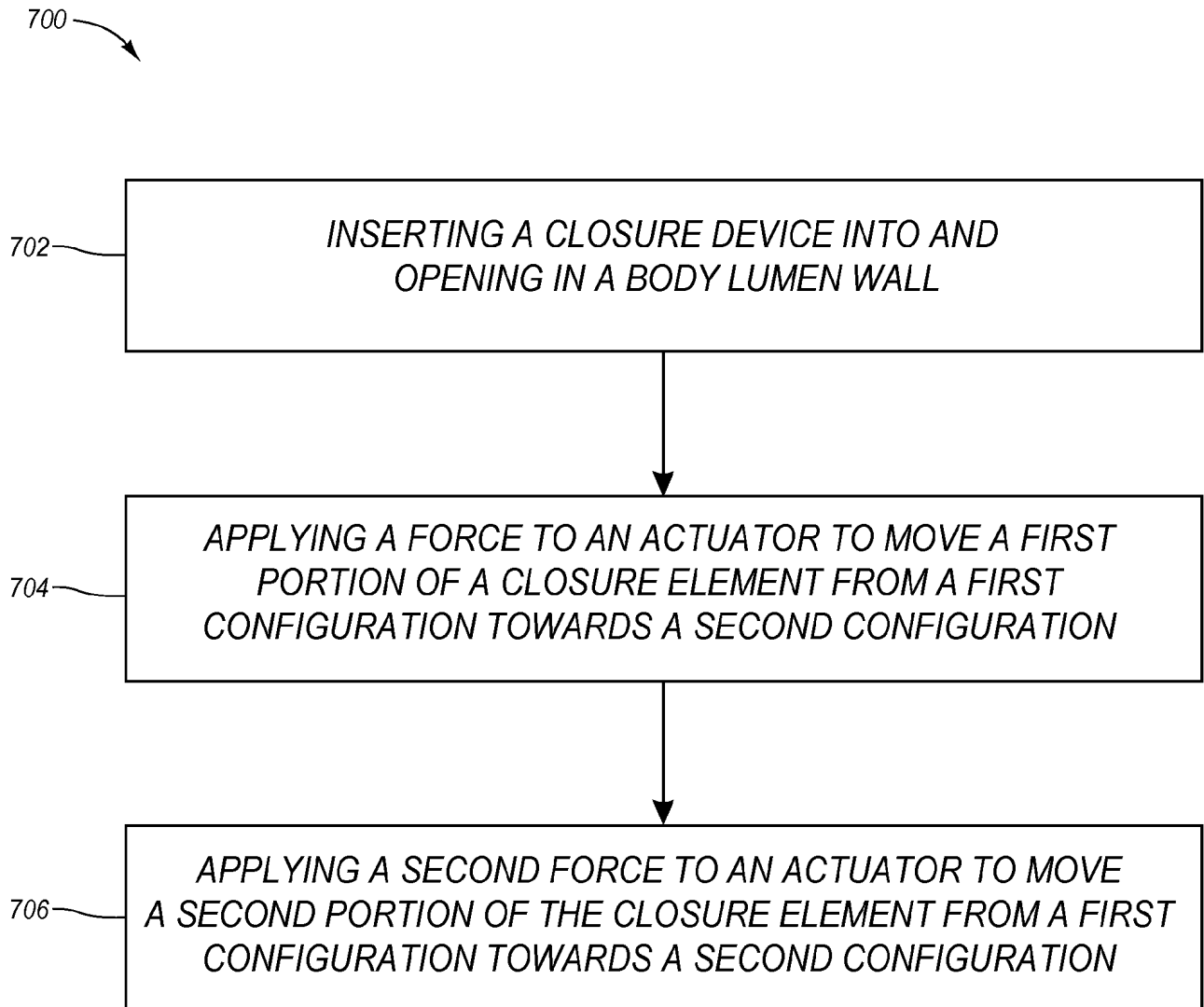

Fig. 18B

**Fig. 19**